

TECHNICAL SPECIFICATION

COLOURS

BODY, FRONT, COUNTER TOP



31 CANADIAN OAK

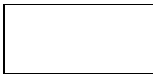

67 WHITE PASTEL



106 LOWLAND NUT

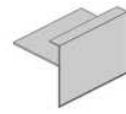

HPL ELEMENTS STRUCTURE



31 CANADIAN OAK

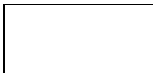

67 WHITE PASTEL



106 LOWLAND NUT

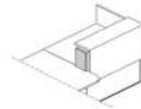
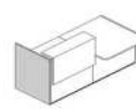

CORNER UNIT

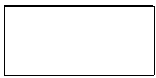

73 HIGH GLOSS  
WHITE



101 HIGH GLOSS  
BLACK



155 ANTHRACITE  
HIGH GLOSS

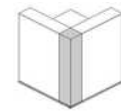

OPTIONAL TOP ELEMENT WITH LIGHT

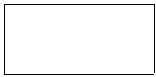

73 HIGH GLOSS  
WHITE



WHITE, LACOBEL



101 HIGH GLOSS  
BLACK



BLACK, LACOBEL



155 ANTHRACITE  
HIGH GLOSS



ANTHRACITE,  
LACOBEL



SUPPORTING LEG WHERE WORKTOPS CONNECT NL41

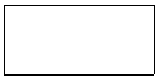

M015 WHITE  
SEMI-MATTE

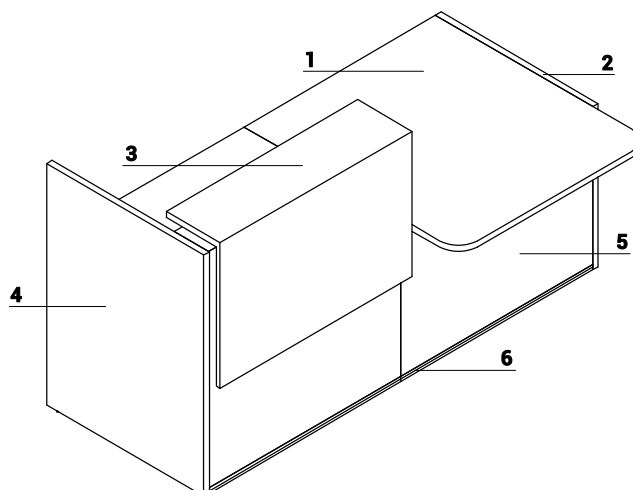

1. **Worktop** - MFC 28mm, PVC edge
2. **Low side panel** - MFC 28mm, PVC edge
3. **Optional top element with lightening** - top melamine board 28mm + Glass LACOBEL 4mm, front melamine board 18mm, all in HPL - gloss
4. **High side panel** - MFC 28mm, PVC edge
5. **Front** - MFC 18mm, PVC edge
6. **Decorative stripe** - PVC, colour: M009 - aluminum semi-matte

TECHNICAL SPECIFICATION

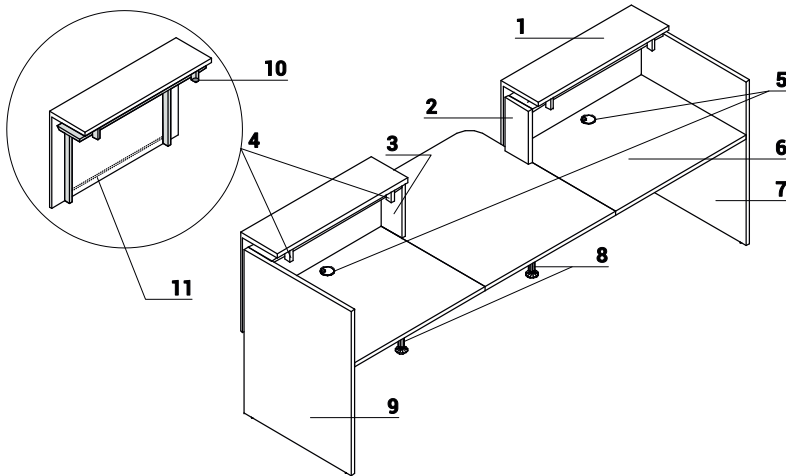

1. **Optional top element with lightening** - top melamine board 28mm + Glass LACOBEL 4mm, front melamine board 18mm, all in HPL - gloss
2. **Side panel linking low and high fronts** - MFC 28mm, PVC edge
3. **Side panel linking low and high fronts** - MFC 28mm, PVC edge
4. **Frame to optional top element with lightening** - metal powder - coated, white colour
5. **Cable grommets** - Ø80mm
6. **Worktop** - MFC 28mm, PVC edge
7. **High side panel** - MFC 28mm, PVC edge
8. **Supporting leg NL41**- required for connecting the tops
9. **High side panel** - MFC 28mm, PVC edge
10. **Light switch**
11. **LED lighting** - over the entire length of the extension, cold white (bluish kind of white)

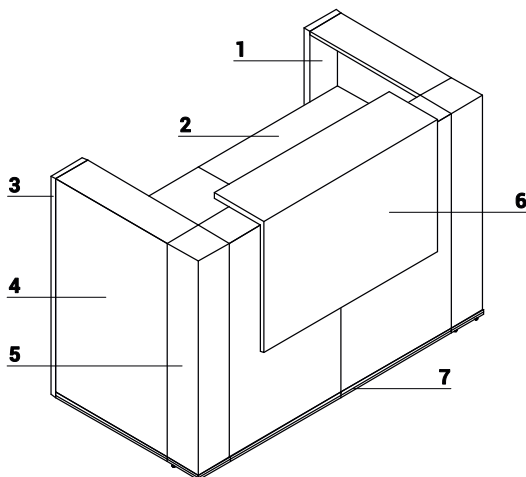

1. **High side panel** - MFC 28mm, PVC edge
2. **Worktop** - MFC 28mm, PVC edge
3. **High side panel** - MFC 28mm, PVC edge
4. **Front** - MFC 18mm, PVC edge
5. **Corner unit** - melamine board covered with HPL - gloss
6. **Optional top element with lightening** - top melamine board 28mm + Glass LACOBEL 4mm, front melamine board 18mm, all in HPL - gloss
7. **Decorative stripe** - PVC, colour: M009 - aluminum semi-matte

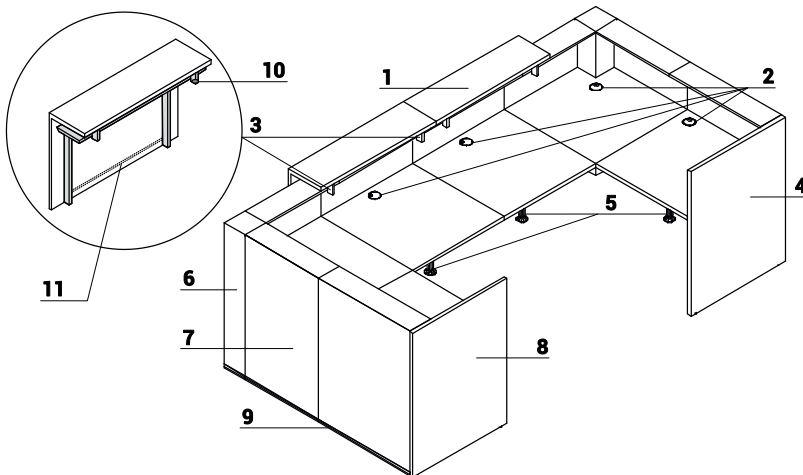

1. **Optional top element with lightening** - top melamine board 28mm + Glass LACOBEL 4mm, front melamine board 18mm, all in HPL - gloss
2. **Cable grommets** - Ø80mm
3. **Frame to optional top element with lightening** - metal powder - coated, white colour
4. **High side panel** - MFC 28mm, PVC edge
5. **Supporting leg NL41**- required for connecting the tops
6. **Corner unit** - melamine board covered with HPL - gloss
7. **Front** - MFC 18mm, PVC edge
8. **High side panel** - MFC 28mm, PVC edge
9. **Decorative stripe** - PVC, colour: M009 - aluminum semi-matte
10. **Light switch**
11. **LED lighting** - over the entire length of the extension, cold white (bluish kind of white)

TECHNICAL SPECIFICATION

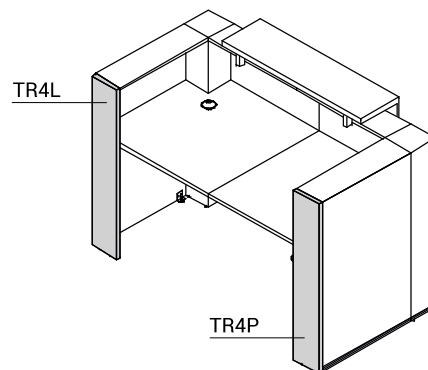
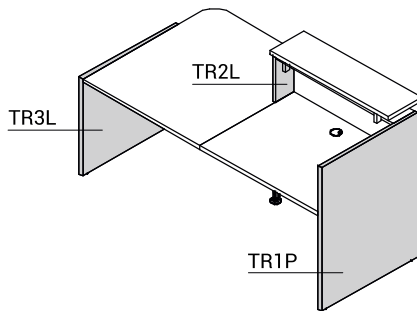
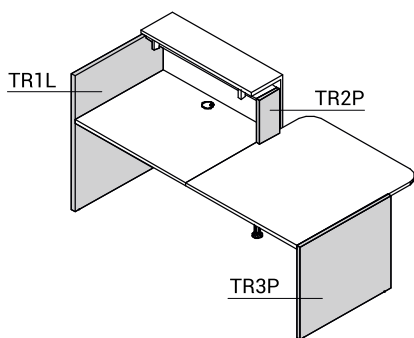

DIMENSIONS

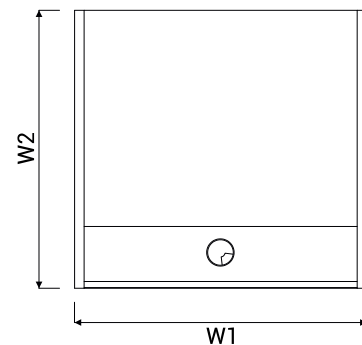
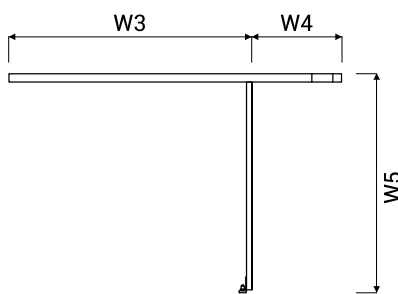
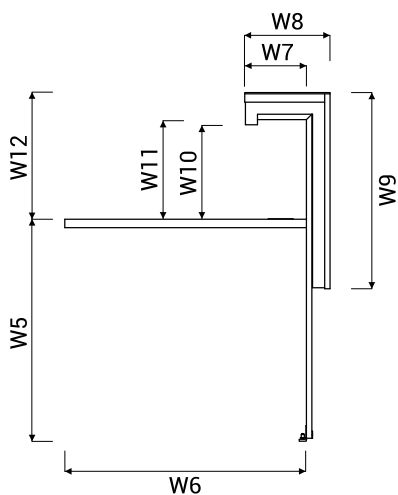

W1 - 856mm | W2 - 820mm | W3 - 818mm | W4 - 302mm | W5 - 740mm | W6 - 800mm | W7 - 205mm | W8 - 282mm | W9 - 650mm | W10 - 315mm | W11 - 322mm | W12 - 419mm

RECEPTION DESKS SYSTEMS

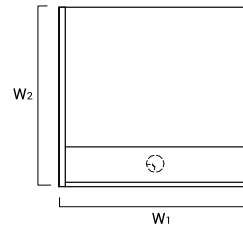
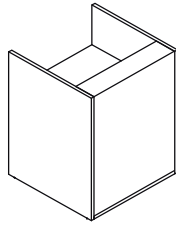

INDEX SYMBOL	DIMENSIONS [mm]					PRICE EUR	kg	m3	pcs	COMPONENTS
	W <sub>1</sub>	W <sub>2</sub>	D <sub>1</sub>	D <sub>2</sub>	H					
<b>TRA13</b>	856	820	-	-	1090	425,-	59.0	0.124	3	TR1L+TR08+TR1P

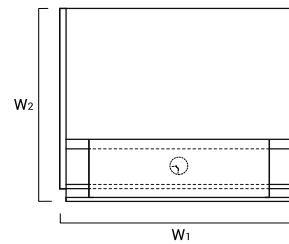
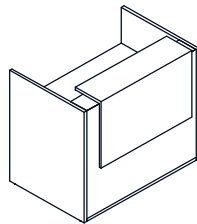

INDEX SYMBOL	DIMENSIONS [mm]					PRICE EUR	kg	m3	pcs	COMPONENTS
	W <sub>1</sub>	W <sub>2</sub>	D <sub>1</sub>	D <sub>2</sub>	H					
<b>TRA14</b>	1056	877	-	-	1159	1 025,-	83.0	0.320	4	TR1L+TR10+TR99+TR1P
<b>TRA15</b>	1256	877	-	-	1159	1 040,-	87.0	0.332	4	TR1L+TR12+TR99+TR1P
<b>TRA16</b>	1456	877	-	-	1159	1 055,-	89.0	0.344	4	TR1L+TR14+TR99+TR1P

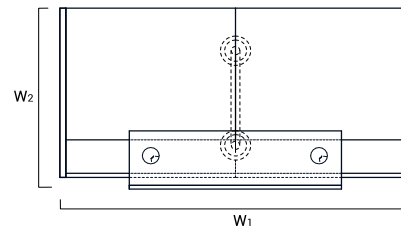
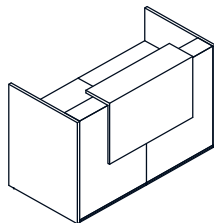

INDEX SYMBOL	DIMENSIONS [mm]					PRICE EUR	kg	m3	pcs	COMPONENTS
	W <sub>1</sub>	W <sub>2</sub>	D <sub>1</sub>	D <sub>2</sub>	H					
<b>TRA17</b>	1656	877	-	-	1159	1 290,-	103.0	0.425	6	TR1L+2xTR08+TR99+TR1P+NL41
<b>TRA18</b>	2056	877	-	-	1159	1 330,-	117.0	0.449	6	TR1L+2xTR10+TR99+TR1P+NL41
<b>TRA19</b>	2456	877	-	-	1159	1 360,-	125.0	0.473	6	TR1L+2xTR12+TR99+TR1P+NL41
<b>TRA20</b>	2856	877	-	-	1159	1 390,-	129.0	0.498	6	TR1L+2xTR14+TR99+TR1P+NL41

DESCRIPTION

- NET WEIGHT

VOLUME

NUMBER OF PACKAGES

RECEPTION DESKS SYSTEMS

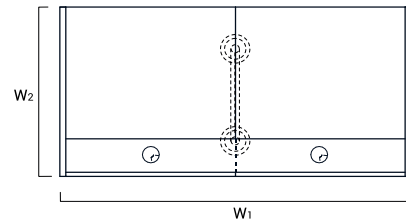
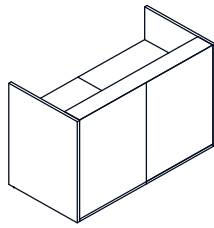

INDEX SYMBOL	DIMENSIONS [mm]					PRICE EUR	kg	m3	pcs	COMPONENTS
	W <sub>1</sub>	W <sub>2</sub>	D <sub>1</sub>	D <sub>2</sub>	H					
TRA117	1656	820	-	-	1090	710,-	86.0	0.242	5	TR1L+2xTR08+TR1P+NL41
TRA118	2056	820	-	-	1090	750,-	100.0	0.266	5	TR1L+2xTR10+TR1P+NL41
TRA119	2456	820	-	-	1090	785,-	108.0	0.290	5	TR1L+2xTR12+TR1P+NL41
TRA120	2856	820	-	-	1090	815,-	112.0	0.314	5	TR1L+2xTR14+TR1P+NL41

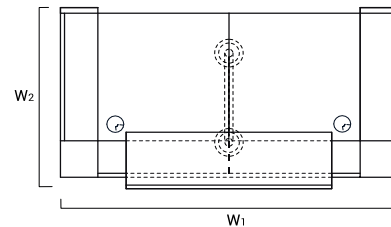
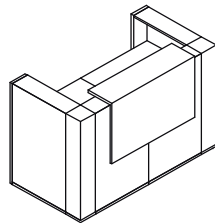

INDEX SYMBOL	DIMENSIONS [mm]					PRICE EUR	kg	m3	pcs	COMPONENTS
	W <sub>1</sub>	W <sub>2</sub>	D <sub>1</sub>	D <sub>2</sub>	H					
TRA42	1640	905	-	-	1159	1 670,-	99.0	0.460	8	TR4L+2xTR90+TR4P+TR99+NL41

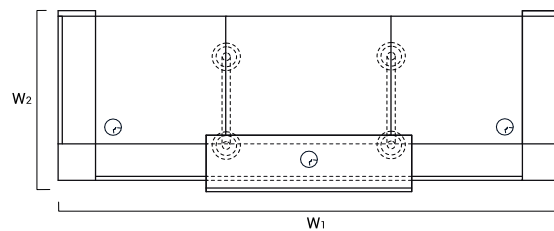
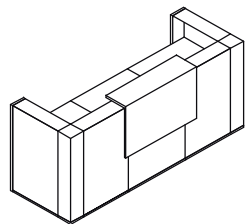

INDEX SYMBOL	DIMENSIONS [mm]					PRICE EUR	kg	m3	pcs	COMPONENTS
	W <sub>1</sub>	W <sub>2</sub>	D <sub>1</sub>	D <sub>2</sub>	H					
TRA21	2440	905	-	-	1159	1 950,-	126.0	0.577	10	TR4L+2xTR90+TR08+TR4P+TR99+2xNL41
TRA22	2640	905	-	-	1159	1 970,-	133.0	0.590	10	TR4L+2xTR90+TR10+TR4P+TR99+2xNL41
TRA23	2840	905	-	-	1159	1 990,-	137.0	0.602	10	TR4L+2xTR90+TR12+TR4P+TR99+2xNL41
TRA24	3040	905	-	-	1159	2 005,-	139.0	0.614	10	TR4L+2xTR90+TR14+TR4P+TR99+2xNL41

DESCRIPTION

- NET WEIGHT

VOLUME

NUMBER OF PACKAGES

RECEPTION DESKS SYSTEMS

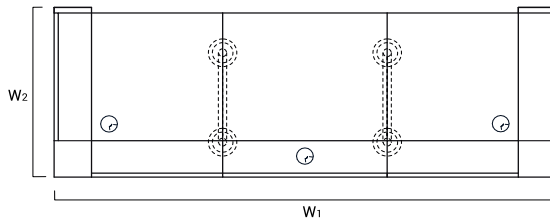
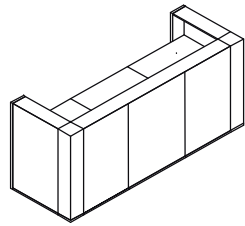

INDEX SYMBOL	DIMENSIONS [mm]					PRICE EUR	kg	m3	pcs	COMPONENTS
	W <sub>1</sub>	W <sub>2</sub>	D <sub>1</sub>	D <sub>2</sub>	H					
TRA121	2440	848	-	-	1090	1 375,-	109.0	0.394	9	TR4L+2xTR90+TR08+TR4P +2xNL41
TRA122	2640	848	-	-	1090	1 395,-	116.0	0.406	9	TR4L+2xTR90+TR10+TR4P +2xNL41
TRA123	2840	848	-	-	1090	1 410,-	120.0	0.418	9	TR4L+2xTR90+TR12+TR4P +2xNL41
TRA124	3040	848	-	-	1090	1 425,-	122.0	0.430	9	TR4L+2xTR90+TR14+TR4P +2xNL41

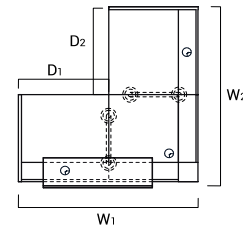
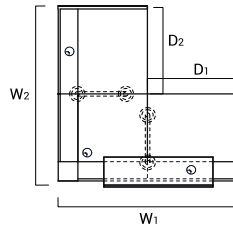
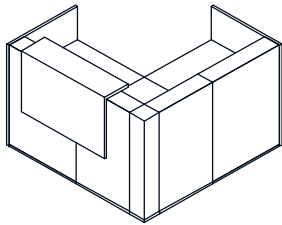

INDEX SYMBOL	DIMENSIONS [mm]					PRICE EUR	kg	m3	pcs	COMPONENTS
	W <sub>1</sub>	W <sub>2</sub>	D <sub>1</sub>	D <sub>2</sub>	H					
TRA25	1648	1705	-	-	1159	1 810,-	141.0	0.586	9	TR1L+TR08+TR90+TR08+TR1P +TR99+2xNL41
TRA26	1848	1705	-	-	1159	1 830,-	148.0	0.598	9	TR1L+TR08+TR90+TR10+TR1P +TR99+2xNL41
TRA27	2048	1705	-	-	1159	1 845,-	152.0	0.611	9	TR1L+TR08+TR90+TR12+TR1P +TR99+2xNL41
TRA28	2248	1705	-	-	1159	1 860,-	154.0	0.623	9	TR1L+TR08+TR90+TR14+TR1P +TR99+2xNL41

DESCRIPTION

- NET WEIGHT

VOLUME

NUMBER OF PACKAGES

RECEPTION DESKS SYSTEMS

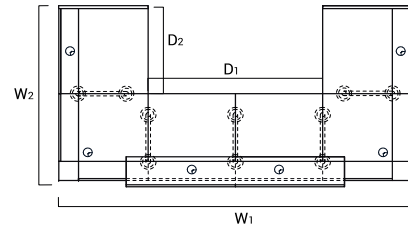
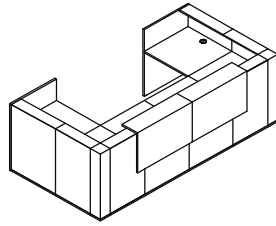

INDEX SYMBOL	DIMENSIONS [mm]					PRICE EUR	kg	m3	pcs	COMPONENTS
	W <sub>1</sub>	W <sub>2</sub>	D <sub>1</sub>	D <sub>2</sub>	H					
TRA29	3240	1705	-	-	1159	3 470,-	250.0	1.166	17	TR1L+2xTR08+2xTR90+2xTR08 +TR1P+2xTR99+5xNL41
TRA30	3640	1705	-	-	1159	3 510,-	264.0	1.190	17	TR1L+2xTR08+2xTR90+2xTR10 +TR1P+2xTR99+5xNL41
TRA31	4040	1705	-	-	1159	3 545,-	272.0	1.214	17	TR1L+2xTR08+2xTR90+2xTR12 +TR1P+2xTR99+5xNL41
TRA32	4440	1705	-	-	1159	3 575,-	276.0	1.239	17	TR1L+2xTR08+2xTR90+2xTR14 +TR1P+2xTR99+5xNL41

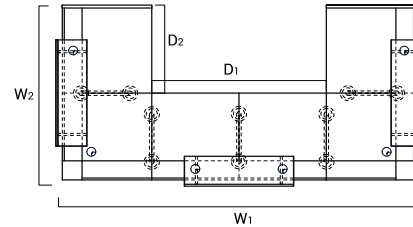
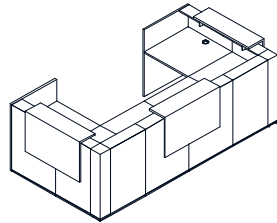

INDEX SYMBOL	DIMENSIONS [mm]					PRICE EUR	kg	m3	pcs	COMPONENTS
	W <sub>1</sub>	W <sub>2</sub>	D <sub>1</sub>	D <sub>2</sub>	H					
TRA129	3354	1705	-	-	1159	4 050,-	267.0	1.349	18	TR1L+2xTR08+2xTR90+2xTR08 +TR1P+3xTR99+5xNL41
TRA130	3754	1705	-	-	1159	4 090,-	281.0	1.374	18	TR1L+2xTR08+2xTR90+2xTR10 +TR1P+3xTR99+5xNL41
TRA131	4154	1705	-	-	1159	4 120,-	289.0	1.398	18	TR1L+2xTR08+2xTR90+2xTR12 +TR1P+3xTR99+5xNL41
TRA132	4554	1705	-	-	1159	4 150,-	293.0	1.422	18	TR1L+2xTR08+2xTR90+2xTR14 +TR1P+3xTR99+5xNL41

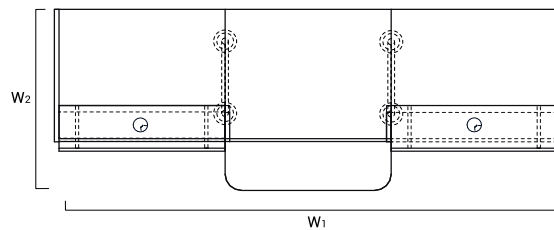
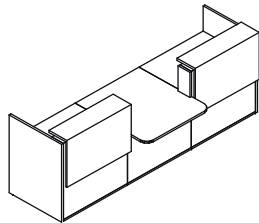

INDEX SYMBOL	DIMENSIONS [mm]					PRICE EUR	kg	m3	pcs	COMPONENTS
	W <sub>1</sub>	W <sub>2</sub>	D <sub>1</sub>	D <sub>2</sub>	H					
TRA33	3056	1120	-	-	1159	2 230,-	169.0	0.793	11	TR1L+TR10+TR2P+TR11+TR2L +TR10+TR1P+2xTR99+2xNL41
TRA34	3456	1120	-	-	1159	2 260,-	177.0	0.817	11	TR1L+TR12+TR2P+TR11+TR2L +TR12+TR1P+2xTR99+2xNL41
TRA35	3856	1120	-	-	1159	2 290,-	181.0	0.841	11	TR1L+TR14+TR2P+TR11+TR2L +TR14+TR1P+2xTR99+2xNL41

DESCRIPTION

- NET WEIGHT

VOLUME

NUMBER OF PACKAGES

RECEPTION DESKS SYSTEMS

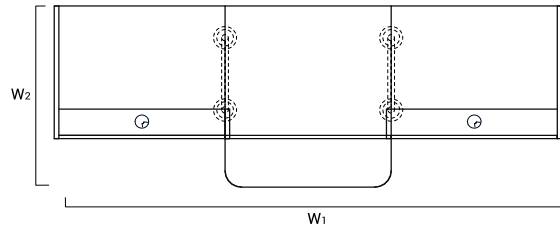
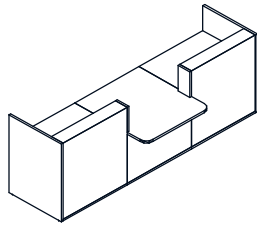

INDEX SYMBOL	DIMENSIONS [mm]					PRICE EUR	⚖️ kg	📦 m3	📦 pcs	COMPONENTS
	W <sub>1</sub>	W <sub>2</sub>	D <sub>1</sub>	D <sub>2</sub>	H					
TRA133	3056	1120	-	-	1090	1 075,-	135.0	0.426	9	TR12+TR10+TR2P+TR11+TR2L+TR10+TR1P+2xNL41
TRA134	3456	1120	-	-	1090	1 105,-	143.0	0.451	9	TR12+TR12+TR2P+TR11+TR2L+TR12+TR1P+2xNL41
TRA135	3856	1120	-	-	1090	1 140,-	147.0	0.475	9	TR12+TR14+TR2P+TR11+TR2L+TR14+TR1P+2xNL41

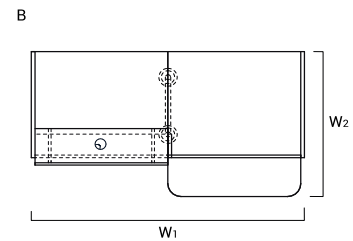
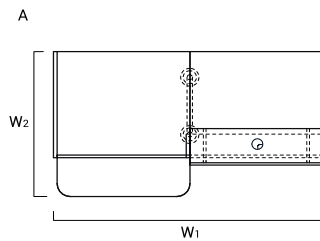
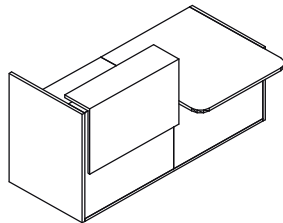

	INDEX SYMBOL	DIMENSIONS [mm]					PRICE EUR	⚖️ kg	📦 m3	📦 pcs	COMPONENTS
		W <sub>1</sub>	W <sub>2</sub>	D <sub>1</sub>	D <sub>2</sub>	H					
A	TRA36L	2056	1120	-	-	1159	1 315,-	111.5	0.467	7	TR1L+TR10+TR2P+TR11+TR3P+TR99+NL41
B	TRA36P	2056	1120	-	-	1159	1 315,-	111.5	0.467	7	TR3L+TR11+TR2L+TR10+TR1P+TR99+NL41
A	TRA37L	2256	1120	-	-	1159	1 330,-	115.5	0.479	7	TR1L+TR12+TR2P+TR11+TR3P+TR99+NL41
B	TRA37P	2256	1120	-	-	1159	1 330,-	115.5	0.479	7	TR3L+TR11+TR2L+TR12+TR1P+TR99+NL41
A	TRA38L	2456	1120	-	-	1159	1 345,-	117.5	0.491	7	TR1L+TR14+TR2P+TR11+TR3P+TR99+NL41
B	TRA38P	2456	1120	-	-	1159	1 345,-	117.5	0.492	7	TR3L+TR11+TR2L+TR14+TR1P+TR99+NL41

DESCRIPTION

⚖️ - NET WEIGHT

📦 VOLUME

📦 NUMBER OF PACKAGES



RECEPTION DESKS SYSTEMS

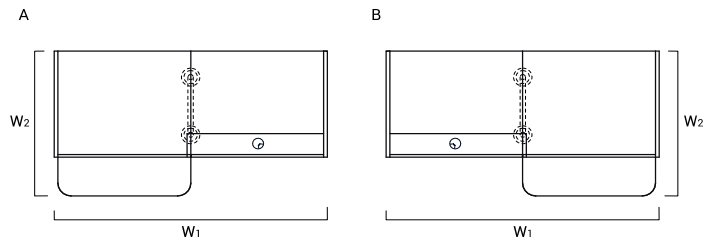
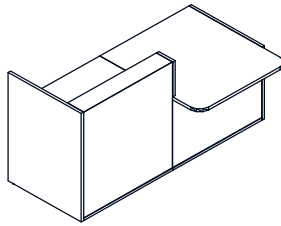

INDEX SYMBOL	DIMENSIONS [mm]					PRICE EUR	kg	m3	pcs	COMPONENTS
	W <sub>1</sub>	W <sub>2</sub>	D <sub>1</sub>	D <sub>2</sub>	H					
A TRA136L	2056	1120	-	-	1090	735,-	94.5	0.283	6	TR1L+TR10+TR2P+TR11+TR3P+NL41
B TRA136P	2056	1120	-	-	1090	735,-	94.5	0.284	6	TR3L+TR11+TR2L+TR10+TR1P+NL41
A TRA137L	2256	1120	-	-	1090	750,-	98.5	0.295	6	TR1L+TR12+TR2P+TR11+TR3P+NL41
B TRA137P	2256	1120	-	-	1090	750,-	98.5	0.296	6	TR3L+TR11+TR2L+TR12+TR1P+NL41
A TRA138L	2456	1120	-	-	1090	765,-	100.5	0.308	6	TR1L+TR14+TR2P+TR11+TR3P+NL41
B TRA138P	2456	1120	-	-	1090	765,-	100.5	0.308	6	TR3L+TR11+TR2L+TR14+TR1P+NL41

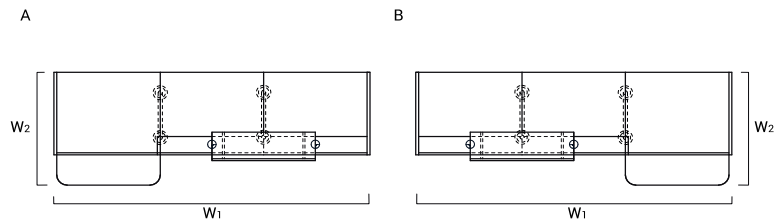
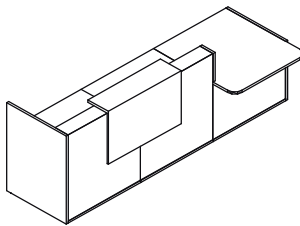



INDEX SYMBOL	DIMENSIONS [mm]					PRICE EUR	kg	m3	pcs	COMPONENTS
	W <sub>1</sub>	W <sub>2</sub>	D <sub>1</sub>	D <sub>2</sub>	H					
A TRA39L	3056	1120	-	-	1159	1 615,-	145.5	0.596	9	TR1L+2xTR10+TR2P+TR11+TR3P+TR99+2xNL41
B TRA39P	3056	1120	-	-	1159	1 615,-	145.5	0.597	9	TR3L+TR11+TR2L+2xTR10+TR1P+TR99+2xNL41
A TRA40L	3456	1120	-	-	1159	1 650,-	153.5	0.620	9	TR1L+2xTR12+TR2P+TR11+TR3P+TR99+2xNL41
B TRA40P	3456	1120	-	-	1159	1 650,-	153.5	0.621	9	TR3L+TR11+TR2L+2xTR12+TR1P+TR99+2xNL41
A TRA41L	3856	1120	-	-	1159	1 680,-	157.5	0.645	9	TR1L+2xTR14+TR2P+TR11+TR3P+TR99+2xNL41
B TRA41P	3856	1120	-	-	1159	1 680,-	157.5	0.645	9	TR3L+TR11+TR2L+2xTR14+TR1P+TR99+2xNL41

DESCRIPTION







- NET WEIGHT

VOLUME

NUMBER OF PACKAGES

PRODUCT ILLUSTRATION	DIMENSIONS [mm]			INDEX SYMBOL	PRICE EUR				COMMENTS
	WIDTH	DEPTH	HEIGHT			kg	m3	pcs	

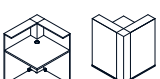
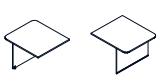
**COMPOSITION ELEMENTS**

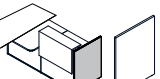
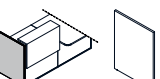
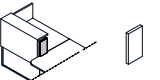
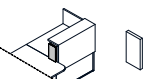

	800	818	1090	<b>TR08</b>	250,-	25.0	0.054	1	
	1000	818	1090	<b>TR10</b>	275,-	32.0	0.067	1	
	1200	818	1090	<b>TR12</b>	290,-	36.0	0.079	1	
	1400	818	1090	<b>TR14</b>	305,-	38.0	0.091	1	
	818	818	1090	<b>TR90</b>	490,-	36.0	0.098	2	
	1000	1120	740	<b>TR11</b>	250,-	30.0	0.092	1	
	1000	282	650	<b>TR99</b>	575,-	17.0	0.183	1	decorative lighted element
	28	820	1090	<b>TR1L</b>	90,-	17.0	0.035	1	side panel for high units -left
	28	820	1090	<b>TR1P</b>	90,-	17.0	0.035	1	side panel for high units - right
	28	182	350	<b>TR2L</b>	21,-	1.5	0.003	1	left upper side panel for combining low and high element
	28	182	350	<b>TR2P</b>	21,-	1.5	0.003	1	right upper side panel for combining low and high element

DESCRIPTION



 - NET WEIGHT

 VOLUME

 NUMBER OF PACKAGES

PRODUCT ILLUSTRATION	DIMENSIONS [mm]			INDEX SYMBOL	PRICE EUR				COMMENTS
	WIDTH	DEPTH	HEIGHT			kg	m3	pcs	

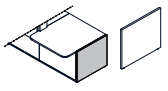
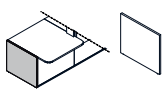
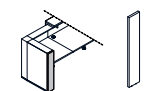
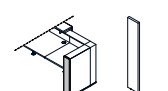
**COMPOSITION ELEMENTS**

	28	820	740	<b>TR3L</b>	72,-	12.0	0.025	1	left side panel for low unit
	28	820	740	<b>TR3P</b>	72,-	12.0	0.025	1	right side panel for low unit
	28	182	1090	<b>TR4L</b>	41,-	4.0	0.008	1	side panel for high units -left
	28	182	1090	<b>TR4P</b>	41,-	4.0	0.008	1	side panel for high units - right
	585	142	712	<b>NL41</b>	35,-	2.0	0.063	1	round profile leg

DESCRIPTION

 - NET WEIGHT

 VOLUME

 NUMBER OF PACKAGES