

# JERA

Design Engineering  
ORLANDINI C.S.R. LAS MOBILI

JERA

Conforme al DLGS 81/2008 (già 626/'94)  
apply to RULE 81/2008 (626/'94)

**IMPORTANTE / it's very important**



Certif. n°07-08/2019

SULL'ORDINE INDICARE SEMPRE IL CODICE COMPLETO A 9 CIFRE  
always indicate on the order the complete 9-digit code

ESEMPIO: PER ORDINARE 1 SCRIVANIA **ART.947** NOCE BALI INDICARE IL CODICE =  
example: to order 1 DESK **ART.947** BALI WALNUT indicate the code =

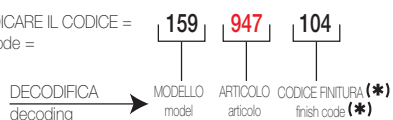

In vigore dal:  
Valid from:  
01/01/2018

Valido fino a nuova emissione  
Valid until new emission

## SOMMARIO / summary

<b>CARTELLA COLORI</b> .....	<b>2</b>
<i>colours samples card</i>	
<b>SCRIVANIE DIREZIONALI</b> .....	<b>4</b>
<i>executive desks</i>	
<b>CASSETTIERA LATERALE</b> .....	<b>5</b>
<i>lateral pedestal</i>	
<b>TOP ACCESS, SOTTOMANO</b> .....	<b>5</b>
<i>top access, desk pad</i>	
<b>PENISOLA FRONTALE PER SCRIVANIE</b> .....	<b>6</b>
<i>front terminal for desks</i>	
<b>TAVOLI DA SALOTTO</b> .....	<b>6</b>
<i>coffee tables</i>	
<b>TAVOLI RIUNIONE</b> .....	<b>6</b>
<i>meeting tables</i>	
<b>MOBILI TOTEM</b> .....	<b>7</b>
<i>totem cabinets</i>	
<b>MOBILI SOSPESI</b> .....	<b>9</b>
<i>suspended cabinets</i>	
<b>MOBILI, TOP E FIANCHI FINALI</b> .....	<b>10</b>
<i>cabinets, top and final side panels</i>	
<b>DESCRIZIONE TECNICA</b> .....	<b>11</b>
<b>TECHNICAL DESCRIPTION</b> .....	<b>13</b>
<b>INDICE DEI CODICI</b> .....	<b>15</b>
<i>codes index</i>	

## CARTELLA COLORI colours samples card

per: PIANI E FRONTALI  
for: tops and fronts



**COD. 12**  
OLMO GREY | GREY ELM



**COD. 30**  
NOCE BALI | BALI WALNUT



**COD. 52**  
FRASSINO BROWN | BROWN ASH



STRUTTURE LEGNO  
wooden structure



**COD. 44**  
STONE GREY | STONE GREY



**COD. 55**  
ANTRACITE | ANTHRACITE



## ECO-PELLE

per: FIANCHI E SCHIENE SCRIVANIE - SOTTOMANO - SPALLA VERTICALE  
for: side panels and back panels - desk pad - vertical panel

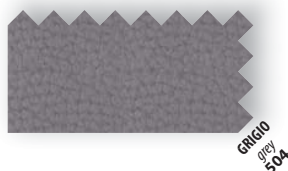

**GRIDO**  
grey  
504



**ARDESIA**  
505

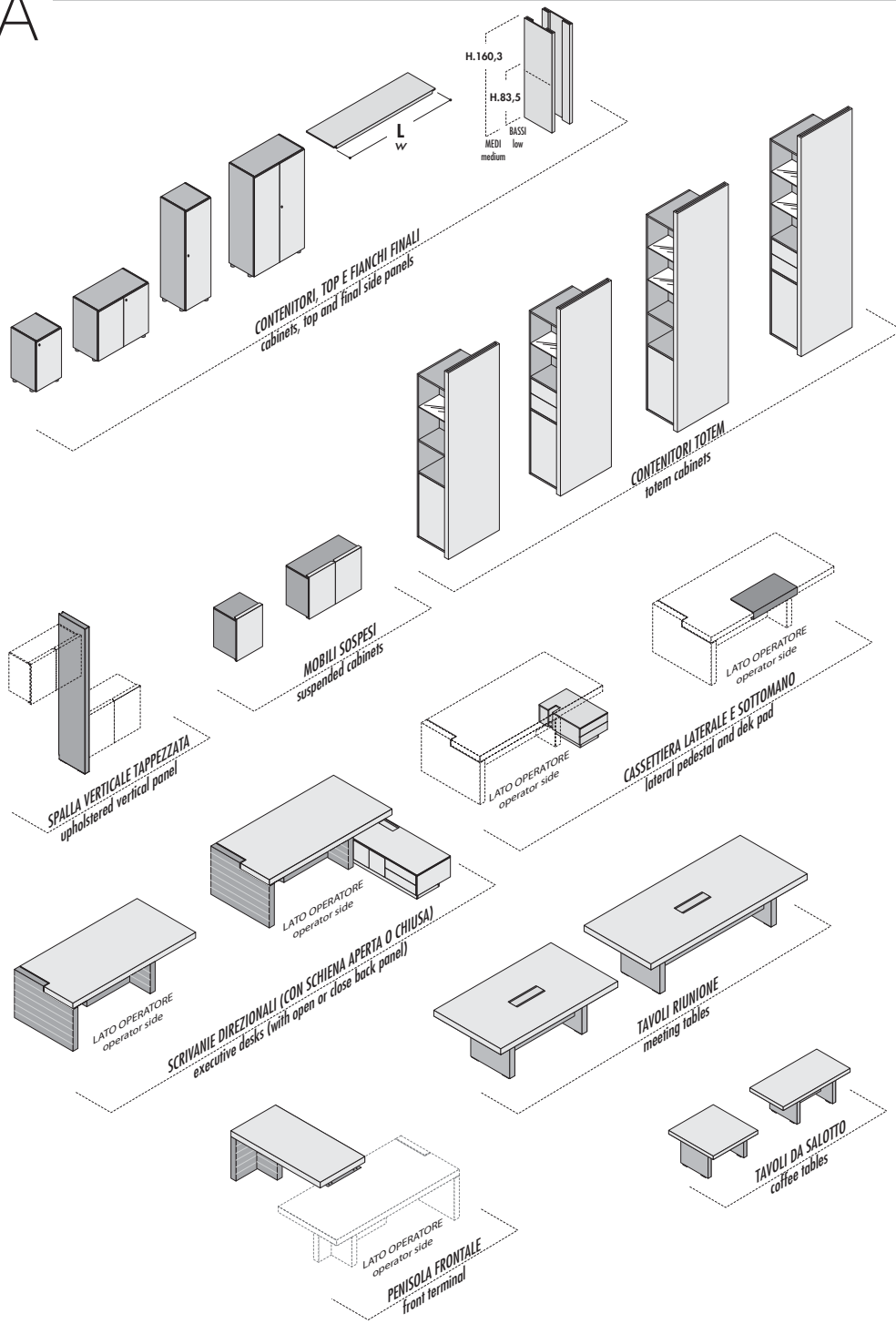



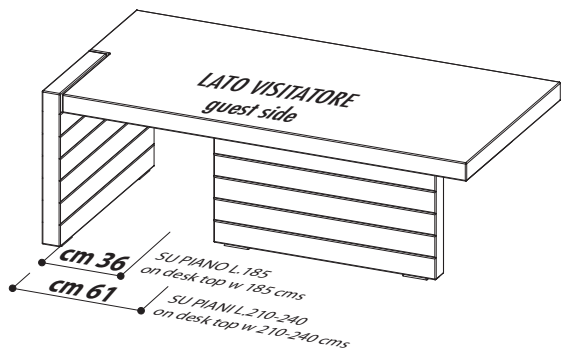

**CON SCHIENA APERTA**  
with open back panel

**CON SCHIENA CHIUSA**  
with close back panel

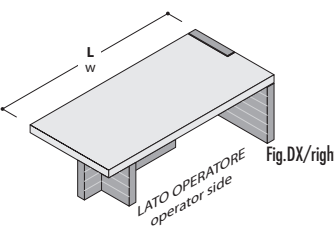
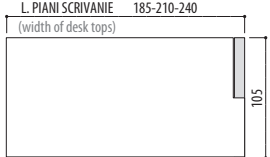
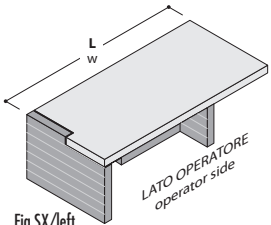
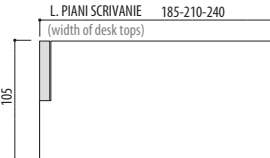
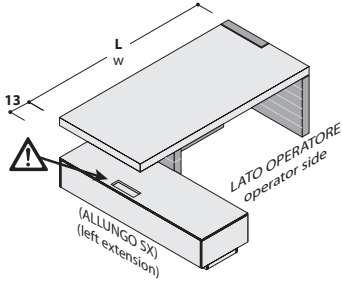
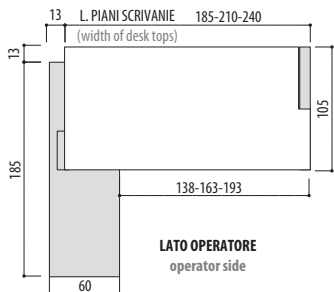

**SCRIVANIE DIREZIONALI**

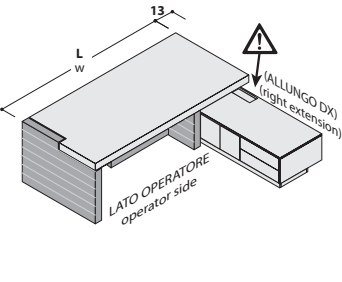
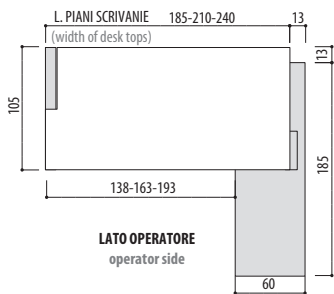
*executive desks*

DESCRIZIONE <i>description</i>	L <i>w</i>	CODICE <i>code</i>	KG	M <sup>3</sup>	COLLI	PREZZO <i>price</i>	(*) CODICE FINITURA <i>(*) finish code</i>																																
SCRIVANIE DIREZIONALI CON FIANCO DX <i>executive desks with right side panel</i>   Fig.DX/right LATO OPERATORE <i>operator side</i>  L. x p.105 x H.76	<b>CON SCHIENA APERTA</b> <i>with open back panel</i>						L. PIANI SCRIVANIE 185-210-240 <i>(width of desk tops)</i>   105  LATO OPERATORE <i>operator side</i>  <table border="1"> <thead> <tr> <th>(*)</th> <th>PIANO</th> <th>BASE IN ECO-PELLE</th> <th>top</th> <th>ECO-PELLE base</th> </tr> </thead> <tbody> <tr> <td>104</td> <td>NOCE BALI</td> <td>GRIGIO</td> <td>bali walnut</td> <td>grey</td> </tr> <tr> <td>105</td> <td>NOCE BALI</td> <td>ARDESIA</td> <td>bali walnut</td> <td>slate</td> </tr> <tr> <td>704</td> <td>FRASSINO BROWN</td> <td>GRIGIO</td> <td>brown ash</td> <td>grey</td> </tr> <tr> <td>804</td> <td>OLMO GREY</td> <td>GRIGIO</td> <td>grey elm</td> <td>grey</td> </tr> <tr> <td>805</td> <td>OLMO GREY</td> <td>ARDESIA</td> <td>grey elm</td> <td>slate</td> </tr> </tbody> </table>	(*)	PIANO	BASE IN ECO-PELLE	top	ECO-PELLE base	104	NOCE BALI	GRIGIO	bali walnut	grey	105	NOCE BALI	ARDESIA	bali walnut	slate	704	FRASSINO BROWN	GRIGIO	brown ash	grey	804	OLMO GREY	GRIGIO	grey elm	grey	805	OLMO GREY	ARDESIA	grey elm	slate		
	(*)	PIANO	BASE IN ECO-PELLE	top	ECO-PELLE base																																		
	104	NOCE BALI	GRIGIO	bali walnut	grey																																		
	105	NOCE BALI	ARDESIA	bali walnut	slate																																		
	704	FRASSINO BROWN	GRIGIO	brown ash	grey																																		
	804	OLMO GREY	GRIGIO	grey elm	grey																																		
	805	OLMO GREY	ARDESIA	grey elm	slate																																		
	DX right	L.185 <b>NEW</b>	159 961 (*)	126	0,568	5		€ 2.060,00																															
		L.210	159 947 (*)	133	0,593	5		€ 2.147,00																															
		L.240	159 949 (*)	151	0,664	5		€ 2.321,00																															
<b>CON SCHIENA CHIUSA</b> <i>with close back panel</i>																																							
DX right	L.210	159 917 (*)	148	0,657	5	€ 2.410,00																																	
	L.240	159 919 (*)	166	0,731	5	€ 2.585,00																																	
SCRIVANIE DIREZIONALI CON FIANCO SX <i>executive desks with left side panel</i>   Fig.SX/left LATO OPERATORE <i>operator side</i>  L. x p.105 x H.76	<b>CON SCHIENA APERTA</b> <i>with open back panel</i>						L. PIANI SCRIVANIE 185-210-240 <i>(width of desk tops)</i>   105  LATO OPERATORE <i>operator side</i>																																
	SX left	L.185 <b>NEW</b>	159 962 (*)	126	0,568	5		€ 2.060,00																															
		L.210	159 950 (*)	133	0,609	5		€ 2.147,00																															
		L.240	159 952 (*)	151	0,641	5		€ 2.321,00																															
	<b>CON SCHIENA CHIUSA</b> <i>with close back panel</i>																																						
	SX left	L.210	159 921 (*)	148	0,673	5		€ 2.410,00																															
		L.240	159 923 (*)	166	0,707	5		€ 2.585,00																															
	SCRIVANIE DIREZIONALI CON FIANCO DX E ALLUNGO SX <i>executive desks with right side panel and left extension</i>   Fig.DX/right LATO OPERATORE <i>operator side</i> (ALLUNGO SX) <i>(left extension)</i>  L. x p.198 x H.76	<b>CON SCHIENA APERTA</b> <i>with open back panel</i>							L. PIANI SCRIVANIE 185-210-240 <i>(width of desk tops)</i>   13 138-163-193 185 60 LATO OPERATORE <i>operator side</i>  <table border="1"> <thead> <tr> <th>(*)</th> <th>PIANO E ALLUNGO</th> <th>BASE IN ECO-PELLE</th> <th>top and extension</th> <th>ECO-PELLE base</th> </tr> </thead> <tbody> <tr> <td>104</td> <td>NOCE BALI</td> <td>GRIGIO</td> <td>bali walnut</td> <td>grey</td> </tr> <tr> <td>105</td> <td>NOCE BALI</td> <td>ARDESIA</td> <td>bali walnut</td> <td>slate</td> </tr> <tr> <td>704</td> <td>FRASSINO BROWN</td> <td>GRIGIO</td> <td>brown ash</td> <td>grey</td> </tr> <tr> <td>804</td> <td>OLMO GREY</td> <td>GRIGIO</td> <td>grey elm</td> <td>grey</td> </tr> <tr> <td>805</td> <td>OLMO GREY</td> <td>ARDESIA</td> <td>grey elm</td> <td>slate</td> </tr> </tbody> </table>	(*)	PIANO E ALLUNGO	BASE IN ECO-PELLE	top and extension	ECO-PELLE base	104	NOCE BALI	GRIGIO	bali walnut	grey	105	NOCE BALI	ARDESIA	bali walnut	slate	704	FRASSINO BROWN	GRIGIO	brown ash	grey	804	OLMO GREY	GRIGIO	grey elm	grey	805	OLMO GREY	ARDESIA	grey elm	slate
		(*)	PIANO E ALLUNGO	BASE IN ECO-PELLE	top and extension	ECO-PELLE base																																	
		104	NOCE BALI	GRIGIO	bali walnut	grey																																	
105		NOCE BALI	ARDESIA	bali walnut	slate																																		
704		FRASSINO BROWN	GRIGIO	brown ash	grey																																		
804		OLMO GREY	GRIGIO	grey elm	grey																																		
805		OLMO GREY	ARDESIA	grey elm	slate																																		
		L.185 <b>NEW</b>	159 963 (*)	274	1,020	10	€ 3.072,00																																
		L.210	159 953 (*)	281	1,046	10	€ 3.159,00																																
		L.240	159 955 (*)	299	1,117	10	€ 3.333,00																																
<b>CON SCHIENA CHIUSA</b> <i>with close back panel</i>																																							
	L.210	159 927 (*)	296	1,110	10	€ 3.422,00																																	
	L.240	159 929 (*)	314	1,184	10	€ 3.597,00																																	
 <b>COMPLETARE SEMPRE CON TOP ACCESS ART.959 O ART.960</b> <i>always complete with top access art.959 or art.960</i>																																							
SCRIVANIE DIREZIONALI CON FIANCO SX E ALLUNGO DX <i>executive desks with left side panel and right extension</i>   Fig.SX/left LATO OPERATORE <i>operator side</i> (ALLUNGO DX) <i>(right extension)</i>  L. x p.198 x H.76	<b>CON SCHIENA APERTA</b> <i>with open back panel</i>						L. PIANI SCRIVANIE 185-210-240 <i>(width of desk tops)</i>   13 138-163-193 105 185 60 LATO OPERATORE <i>operator side</i>																																
		L.185 <b>NEW</b>	159 964 (*)	274	1,020	10		€ 3.072,00																															
		L.210	159 956 (*)	281	1,062	10		€ 3.159,00																															
		L.240	159 958 (*)	299	1,094	10		€ 3.333,00																															
	<b>CON SCHIENA CHIUSA</b> <i>with close back panel</i>																																						
		L.210	159 931 (*)	296	1,126	10		€ 3.422,00																															
		L.240	159 933 (*)	314	1,160	10		€ 3.597,00																															
	 <b>COMPLETARE SEMPRE CON TOP ACCESS ART.959 O ART.960</b> <i>always complete with top access art.959 or art.960</i>																																						



**CASSETTIERA LATERALE**

*lateral pedestal*

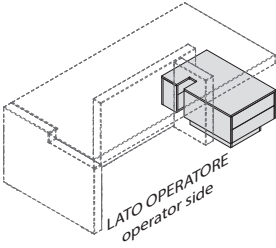
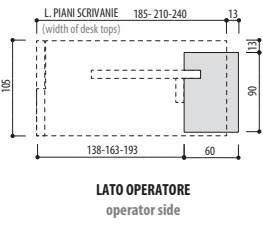
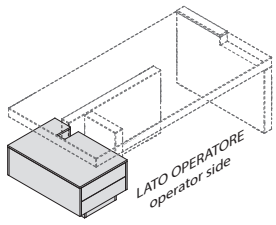
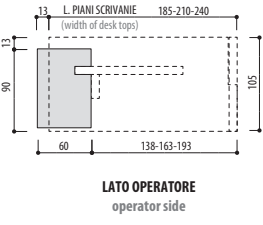
DESCRIZIONE <i>description</i>	L <i>w</i>	CODICE <i>code</i>	KG	M <sup>3</sup>	COLLI	PREZZO <i>price</i>	(*) CODICE FINITURA <i>(*) finish code</i>												
<p>CASSETTIERA LATERALE DX 2 CASSETTI <i>right lateral pedestal 2 drawers</i></p>  <p>L.60 x p.90 x H.44</p>	L.60	159 <b>935</b> (*)	87	0,270	2	€ 654,00													
								<p>PROSPETTO INFORMATIVO <i>information sheet</i></p> <table border="1"> <tr> <td>CASSETTIERA pedestal</td> <td>UTILIZZABILE SU SCRIVANIE usable on desks</td> </tr> <tr> <td>ART.935</td> <td>ART. 950-952-921-923-962</td> </tr> </table>							CASSETTIERA pedestal	UTILIZZABILE SU SCRIVANIE usable on desks	ART.935	ART. 950-952-921-923-962	
CASSETTIERA pedestal	UTILIZZABILE SU SCRIVANIE usable on desks																		
ART.935	ART. 950-952-921-923-962																		
<p>CASSETTIERA LATERALE SX 2 CASSETTI <i>left lateral pedestal 2 drawers</i></p>  <p>L.60 x p.90 x H.44</p>	L.60	159 <b>936</b> (*)	87	0,270	2	€ 654,00													
								<p>PROSPETTO INFORMATIVO <i>information sheet</i></p> <table border="1"> <tr> <td>CASSETTIERA pedestal</td> <td>UTILIZZABILE SU SCRIVANIE usable on desks</td> </tr> <tr> <td>ART.936</td> <td>ART. 947-949-917-919-961</td> </tr> </table>							CASSETTIERA pedestal	UTILIZZABILE SU SCRIVANIE usable on desks	ART.936	ART. 947-949-917-919-961	
CASSETTIERA pedestal	UTILIZZABILE SU SCRIVANIE usable on desks																		
ART.936	ART. 947-949-917-919-961																		
							<table border="1"> <tr> <th>(*)</th> <th></th> <th></th> </tr> <tr> <td>100</td> <td>NOCE BALI</td> <td>bali walnut</td> </tr> <tr> <td>700</td> <td>FRASSINO BROWN</td> <td>brown ash</td> </tr> <tr> <td>800</td> <td>OLMO GREY</td> <td>grey elm</td> </tr> </table>	(*)			100	NOCE BALI	bali walnut	700	FRASSINO BROWN	brown ash	800	OLMO GREY	grey elm
(*)																			
100	NOCE BALI	bali walnut																	
700	FRASSINO BROWN	brown ash																	
800	OLMO GREY	grey elm																	

**TOP ACCESS, SOTTOMANO**

*top access, desk pad*

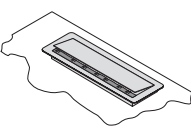
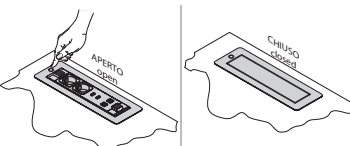
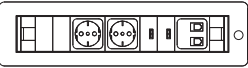
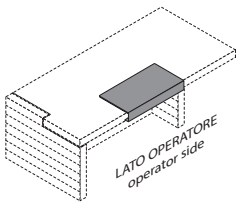
<p>TOP ACCESS STANDARD <i>standard top access</i></p>  <p>L.39 x p.11,2 x H.2,5</p>	L.39	159 <b>959</b> (*)	0,6	0,004	1	€ 85,00										
<p>TOP ACCESS MULTIFUNZIONE <i>multifunctions top access</i></p>  <p>L.39 x p.11,2 x H.10</p>	L.39	159 <b>960</b> (*)	2	0,013	1	€ 578,00	<table border="1"> <tr> <th>(*)</th> <th></th> <th></th> </tr> <tr> <td>500</td> <td>NERO</td> <td>black</td> </tr> </table>	(*)			500	NERO	black			
								(*)								
500	NERO	black														
<p>2 PRESE STANDARD ITALIA/GERMANIA(SCHUKO) 2 KIT DATI RJ45 CAT.6 - 2 USB CHARGER FAST 2 Italy/Germany standard sockets (SCHUKO) and data kit RJ45 CAT.6 - 2 USB CHARGER FAST</p> 																
<p>SOTTOMANO PER SCRIVANIE <i>desk pad</i></p>  <p>L.90 x p.60 x H.9,8</p>	L.90	159 <b>932</b> (*)	9	0,078	1	€ 260,00	<table border="1"> <tr> <th>(*)</th> <th>ECO-PELLE</th> <th>ECO-PELLE</th> </tr> <tr> <td>504</td> <td>GRIGIO</td> <td>grey</td> </tr> <tr> <td>505</td> <td>ARDESIA</td> <td>slate</td> </tr> </table>	(*)	ECO-PELLE	ECO-PELLE	504	GRIGIO	grey	505	ARDESIA	slate
								(*)	ECO-PELLE	ECO-PELLE						
504	GRIGIO	grey														
505	ARDESIA	slate														

JERA



## PENISOLA FRONTALE PER SCRIVANIE

front terminal for desks

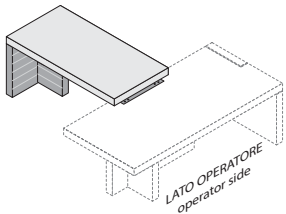
DESCRIZIONE description	L w	CODICE code	KG	M <sup>3</sup>	COLLI	PREZZO price	(*) CODICE FINITURA (* finish code)																														
PENISOLA FRONTALE PER SCRIVANIE front terminal for desks    L.160 x p.80 x H.76	L.160	159 910 (*)	64,5	0,277	4	€ 1.336,00	<table border="1"> <thead> <tr> <th>(*)</th> <th>PIANO</th> <th>BASE IN ECO-PELLE</th> <th>top</th> <th>ECO-PELLE base</th> </tr> </thead> <tbody> <tr> <td>104</td> <td>NOCE BALI</td> <td>GRIGIO</td> <td>bali walnut</td> <td>grey</td> </tr> <tr> <td>105</td> <td>NOCE BALI</td> <td>ARDESIA</td> <td>bali walnut</td> <td>slate</td> </tr> <tr> <td>704</td> <td>FRASSINO BROWN</td> <td>GRIGIO</td> <td>brown ash</td> <td>grey</td> </tr> <tr> <td>804</td> <td>OLMO GREY</td> <td>GRIGIO</td> <td>grey elm</td> <td>grey</td> </tr> <tr> <td>805</td> <td>OLMO GREY</td> <td>ARDESIA</td> <td>grey elm</td> <td>slate</td> </tr> </tbody> </table>	(*)	PIANO	BASE IN ECO-PELLE	top	ECO-PELLE base	104	NOCE BALI	GRIGIO	bali walnut	grey	105	NOCE BALI	ARDESIA	bali walnut	slate	704	FRASSINO BROWN	GRIGIO	brown ash	grey	804	OLMO GREY	GRIGIO	grey elm	grey	805	OLMO GREY	ARDESIA	grey elm	slate
							(*)	PIANO	BASE IN ECO-PELLE	top	ECO-PELLE base																										
104	NOCE BALI	GRIGIO	bali walnut	grey																																	
105	NOCE BALI	ARDESIA	bali walnut	slate																																	
704	FRASSINO BROWN	GRIGIO	brown ash	grey																																	
804	OLMO GREY	GRIGIO	grey elm	grey																																	
805	OLMO GREY	ARDESIA	grey elm	slate																																	

## TAVOLI DA SALOTTO

coffee tables

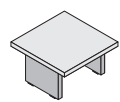
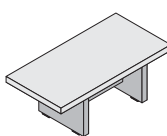
TAVOLO DA SALOTTO QUADRATO L.80 squared coffee table w 80 cms    L.80 x p.80 x H.40	L.80	159 911 (*)	26,5	0,077	4	€ 557,00	<table border="1"> <thead> <tr> <th>(*)</th> <th>PIANO</th> <th>FIANCHI IN ECO-PELLE</th> <th>top</th> <th>ECO-PELLE side panels</th> </tr> </thead> <tbody> <tr> <td>104</td> <td>NOCE BALI</td> <td>GRIGIO</td> <td>bali walnut</td> <td>grey</td> </tr> <tr> <td>105</td> <td>NOCE BALI</td> <td>ARDESIA</td> <td>bali walnut</td> <td>slate</td> </tr> <tr> <td>704</td> <td>FRASSINO BROWN</td> <td>GRIGIO</td> <td>brown ash</td> <td>grey</td> </tr> <tr> <td>804</td> <td>OLMO GREY</td> <td>GRIGIO</td> <td>grey elm</td> <td>grey</td> </tr> <tr> <td>805</td> <td>OLMO GREY</td> <td>ARDESIA</td> <td>grey elm</td> <td>slate</td> </tr> </tbody> </table>	(*)	PIANO	FIANCHI IN ECO-PELLE	top	ECO-PELLE side panels	104	NOCE BALI	GRIGIO	bali walnut	grey	105	NOCE BALI	ARDESIA	bali walnut	slate	704	FRASSINO BROWN	GRIGIO	brown ash	grey	804	OLMO GREY	GRIGIO	grey elm	grey	805	OLMO GREY	ARDESIA	grey elm	slate
							(*)	PIANO	FIANCHI IN ECO-PELLE	top	ECO-PELLE side panels																										
104	NOCE BALI	GRIGIO	bali walnut	grey																																	
105	NOCE BALI	ARDESIA	bali walnut	slate																																	
704	FRASSINO BROWN	GRIGIO	brown ash	grey																																	
804	OLMO GREY	GRIGIO	grey elm	grey																																	
805	OLMO GREY	ARDESIA	grey elm	slate																																	
TAVOLO DA SALOTTO RETTANGOLARE L.120 rectangular coffee table w 120 cms    L.120 x p.60 x H.40	L.120	159 912 (*)	30,5	0,081	4	€ 616,00	SCHIENE IN MELAMINICO: ANTRACITE O STONE GREY melamine back panels: anthracite or stone grey																														

## TAVOLI RIUNIONE

meeting tables

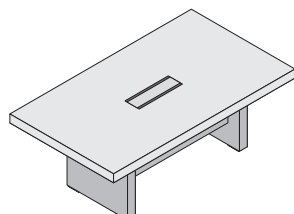
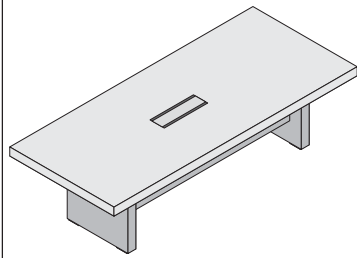
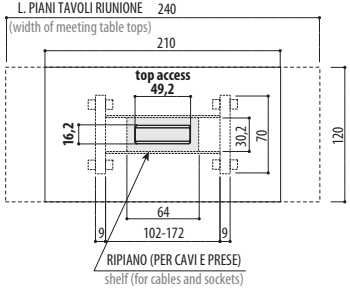
TAVOLO RIUNIONE L.210 meeting table w 210 cms    L.210 x p.120 x H.76	L.210	159 913 (*)	145	0,551	5	€ 2.025,00	<table border="1"> <thead> <tr> <th>(*)</th> <th>PIANO</th> <th>FIANCHI IN ECO-PELLE</th> <th>top</th> <th>ECO-PELLE side panels</th> </tr> </thead> <tbody> <tr> <td>104</td> <td>NOCE BALI</td> <td>GRIGIO</td> <td>bali walnut</td> <td>grey</td> </tr> <tr> <td>105</td> <td>NOCE BALI</td> <td>ARDESIA</td> <td>bali walnut</td> <td>slate</td> </tr> <tr> <td>704</td> <td>FRASSINO BROWN</td> <td>GRIGIO</td> <td>brown ash</td> <td>grey</td> </tr> <tr> <td>804</td> <td>OLMO GREY</td> <td>GRIGIO</td> <td>grey elm</td> <td>grey</td> </tr> <tr> <td>805</td> <td>OLMO GREY</td> <td>ARDESIA</td> <td>grey elm</td> <td>slate</td> </tr> </tbody> </table>	(*)	PIANO	FIANCHI IN ECO-PELLE	top	ECO-PELLE side panels	104	NOCE BALI	GRIGIO	bali walnut	grey	105	NOCE BALI	ARDESIA	bali walnut	slate	704	FRASSINO BROWN	GRIGIO	brown ash	grey	804	OLMO GREY	GRIGIO	grey elm	grey	805	OLMO GREY	ARDESIA	grey elm	slate
							(*)	PIANO	FIANCHI IN ECO-PELLE	top	ECO-PELLE side panels																										
104	NOCE BALI	GRIGIO	bali walnut	grey																																	
105	NOCE BALI	ARDESIA	bali walnut	slate																																	
704	FRASSINO BROWN	GRIGIO	brown ash	grey																																	
804	OLMO GREY	GRIGIO	grey elm	grey																																	
805	OLMO GREY	ARDESIA	grey elm	slate																																	
							SCHIENE E RIPIANO IN MELAMINICO: ANTRACITE O STONE GREY back panels and shelf in melamine: anthracite or stone grey																														
TAVOLO RIUNIONE L.280 meeting table w 280 cms    L.280 x p.120 x H.76	L.280	159 914 (*)	166	0,667	5	€ 2.458,00																															



**MOBILI TOTEM**

*totem cabinets*

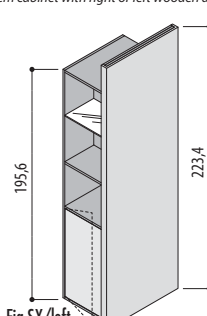
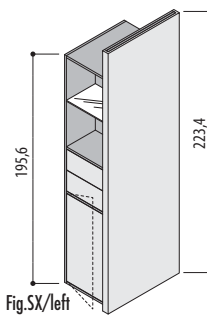
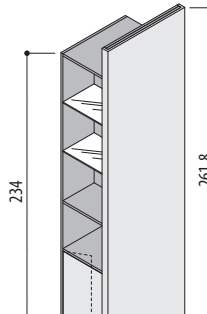
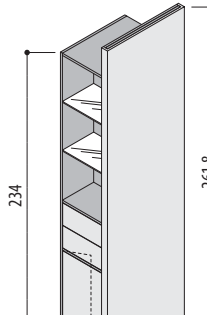
DESCRIZIONE <i>description</i>	L <i>w</i>	CODICE <i>code</i>	KG	M <sup>3</sup>	COLLI	PREZZO <i>price</i>	(*) CODICE FINITURA <i>(*) finish code</i>				
							PANNELLO FRONTALE ED ANTA	STRUTTURA E PANNELLO INTERNO	<i>front panel and door</i>	<i>structure and inside panel</i>	
MOBILE TOTEM CON ANTA DX O SX <i>totem cabinet with right or left wooden door</i>   Fig.SX/left L.70 x p.48,5 x H.223,4	L.70	159 <b>965</b> (*)	107	0,269	6	€ 1.086,00					
							130	NOCE BALI	STONE GREY	<i>bali walnut</i>	<i>stone grey</i>
							160	NOCE BALI	ANTRACITE	<i>bali walnut</i>	<i>anthracite</i>
							730	FRASSINO BROWN	STONE GREY	<i>brown ash</i>	<i>stone grey</i>
							830	OLMO GREY	STONE GREY	<i>grey elm</i>	<i>stone grey</i>
ANTA CON POSSIBILITA' DI MONTAGGIO SUL LATO SX O DX DEL TOTEM <i>door with mounting options on the left or right side of the totem</i>							860	OLMO GREY	ANTRACITE	<i>grey elm</i>	<i>anthracite</i>
RIPIANI IN VETRO TEMPERATO FUME' sp.mm 8 <i>smoke tempered glass shelves thick. mm 8</i>											
MOBILE TOTEM CON ANTA DX O SX E 2 CASSETTI <i>totem cabinet with right or left wooden door and 2 drawers</i>   Fig.SX/left L.70 x p.48,5 x H.223,4	L.70	159 <b>966</b> (*)	122	0,427	7	€ 1.274,00					
							130	NOCE BALI	STONE GREY	<i>bali walnut</i>	<i>stone grey</i>
							160	NOCE BALI	ANTRACITE	<i>bali walnut</i>	<i>anthracite</i>
							730	FRASSINO BROWN	STONE GREY	<i>brown ash</i>	<i>stone grey</i>
							830	OLMO GREY	STONE GREY	<i>grey elm</i>	<i>stone grey</i>
ANTA E CASSETTI CON POSSIBILITA' DI MONTAGGIO SUL LATO SX O DX DEL TOTEM <i>door and drawers with mounting options on the left or right side of the totem</i>							860	OLMO GREY	ANTRACITE	<i>grey elm</i>	<i>anthracite</i>
RIPIANI IN VETRO TEMPERATO FUME' sp.mm 8 <i>smoke tempered glass shelves thick. mm 8</i>											
MOBILE TOTEM CON ANTA DX O SX <i>totem cabinet with right or left wooden door</i>   Fig.SX/left L.70 x p.48,5 x H.261,8	L.70	159 <b>968</b> (*)	128	0,323	7	€ 1.270,00					
							130	NOCE BALI	STONE GREY	<i>bali walnut</i>	<i>stone grey</i>
							160	NOCE BALI	ANTRACITE	<i>bali walnut</i>	<i>anthracite</i>
							730	FRASSINO BROWN	STONE GREY	<i>brown ash</i>	<i>stone grey</i>
							830	OLMO GREY	STONE GREY	<i>grey elm</i>	<i>stone grey</i>
ANTA CON POSSIBILITA' DI MONTAGGIO SUL LATO SX O DX DEL TOTEM <i>door with mounting options on the left or right side of the totem</i>							860	OLMO GREY	ANTRACITE	<i>grey elm</i>	<i>anthracite</i>
RIPIANI IN VETRO TEMPERATO FUME' sp.mm 8 <i>smoke tempered glass shelves thick. mm 8</i>											
MOBILE TOTEM CON ANTA DX O SX E 2 CASSETTI <i>totem cabinet with right or left wooden door and 2 drawers</i>   Fig.SX/left L.70 x p.48,5 x H.261,8	L.70	159 <b>969</b> (*)	144	0,482	8	€ 1.457,00					
							130	NOCE BALI	STONE GREY	<i>bali walnut</i>	<i>stone grey</i>
							160	NOCE BALI	ANTRACITE	<i>bali walnut</i>	<i>anthracite</i>
							730	FRASSINO BROWN	STONE GREY	<i>brown ash</i>	<i>stone grey</i>
							830	OLMO GREY	STONE GREY	<i>grey elm</i>	<i>stone grey</i>
ANTA E CASSETTI CON POSSIBILITA' DI MONTAGGIO SUL LATO SX O DX DEL TOTEM <i>door and drawers with mounting options on the left or right side of the totem</i>							860	OLMO GREY	ANTRACITE	<i>grey elm</i>	<i>anthracite</i>
RIPIANI IN VETRO TEMPERATO FUME' sp.mm 8 <i>smoke tempered glass shelves thick. mm 8</i>											

JERA



**MOBILE TOTEM**  
totem cabinet

**ESEMPIO:**  
Example:

STRUTTURA E PANNELLO INTERNO  
structure and inside panel

VETRO TEMPERATO FUME' sp.mm 8  
smoke tempered glass thick. mm 8

LED

CASSETTI  
drawers

ANTA SX  
left door

LED

ON/OFF  
DIMMER



PANNELLO FRONTALE  
front panel

DX/right

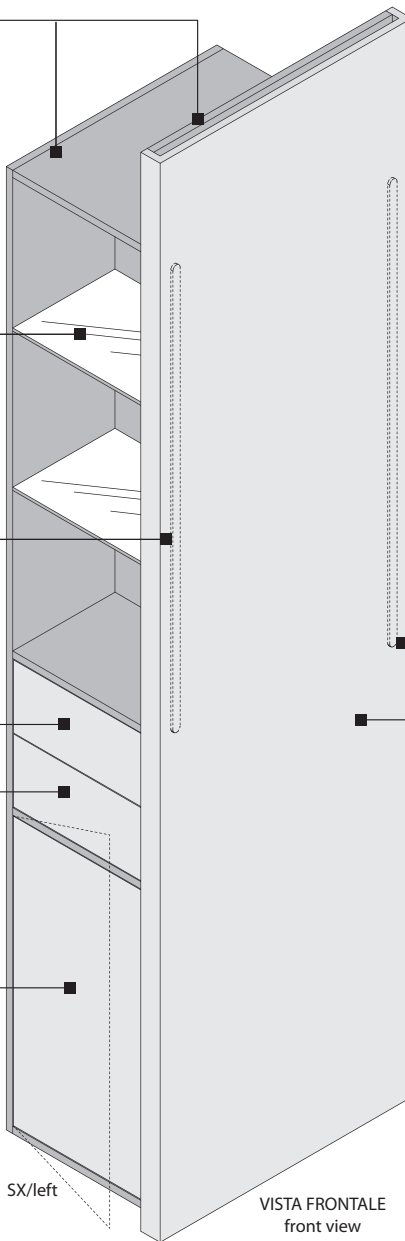

**- VISTA IN PIANTA -**  
plan view

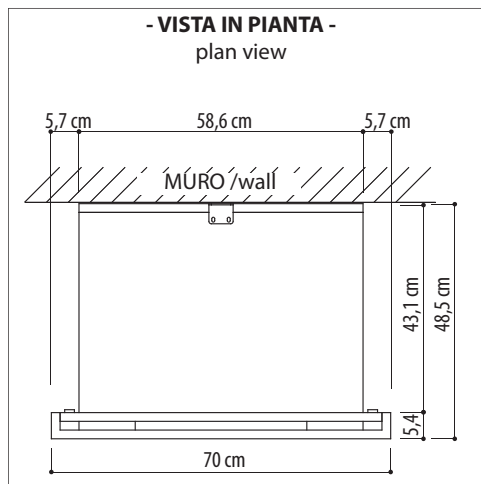

SX/left

VISTA FRONTALE  
front view

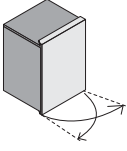
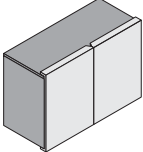
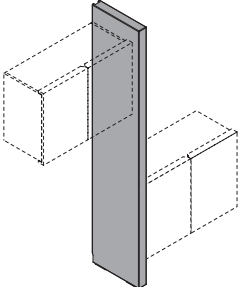

**MOBILI SOSPESI**  
suspended cabinets

DESCRIZIONE description	L w	CODICE code	KG	M <sup>3</sup>	COLLI	PREZZO price	(*) CODICE FINITURA (* finish code)																														
MOBILE SOSPESO L.45 CON 1 ANTA LEGNO DX O SX CON CHIUSURA AMMORTIZZATA suspended cabinet w 45 cms with 1 soft-close right or left wooden door    L.45 x p.40 x H.62,7	L.45	159 976 (*)	17	0,152	3	€ 244,00																															
								<table border="1"> <thead> <tr> <th>(*)</th> <th>ANTE</th> <th>STRUTTURA</th> <th>doors</th> <th>struttura</th> </tr> </thead> <tbody> <tr> <td>130</td> <td>NOCE BALI</td> <td>STONE GREY</td> <td>bali walnut</td> <td>stone grey</td> </tr> <tr> <td>160</td> <td>NOCE BALI</td> <td>ANTRACITE</td> <td>bali walnut</td> <td>antracite</td> </tr> <tr> <td>730</td> <td>FRASSINO BROWN</td> <td>STONE GREY</td> <td>brown ash</td> <td>stone grey</td> </tr> <tr> <td>830</td> <td>OLMO GREY</td> <td>STONE GREY</td> <td>grey elm</td> <td>stone grey</td> </tr> <tr> <td>860</td> <td>OLMO GREY</td> <td>ANTRACITE</td> <td>grey elm</td> <td>antracite</td> </tr> </tbody> </table>	(*)	ANTE	STRUTTURA	doors	struttura	130	NOCE BALI	STONE GREY	bali walnut	stone grey	160	NOCE BALI	ANTRACITE	bali walnut	antracite	730	FRASSINO BROWN	STONE GREY	brown ash	stone grey	830	OLMO GREY	STONE GREY	grey elm	stone grey	860	OLMO GREY	ANTRACITE	grey elm
(*)	ANTE	STRUTTURA	doors	struttura																																	
130	NOCE BALI	STONE GREY	bali walnut	stone grey																																	
160	NOCE BALI	ANTRACITE	bali walnut	antracite																																	
730	FRASSINO BROWN	STONE GREY	brown ash	stone grey																																	
830	OLMO GREY	STONE GREY	grey elm	stone grey																																	
860	OLMO GREY	ANTRACITE	grey elm	antracite																																	
MOBILE SOSPESO L.90 CON 2 ANTE LEGNO CON CHIUSURA AMMORTIZZATA suspended cabinet w 90 cms with 2 soft-close wooden doors    L.90 x p.40 x H.62,7	L.90	159 980 (*)	27	0,259	4	€ 362,00																															
SPALLA VERTICALE TAPPEZZATA upholstered vertical panel    sp.9 x p.50 x H.220		159 983 (*)	27	0,186	1	€ 498,00																															
								<table border="1"> <thead> <tr> <th>(*)</th> <th>ECO-PELLE</th> <th>ECO-PELLE</th> </tr> </thead> <tbody> <tr> <td>504</td> <td>GRIGIO</td> <td>grey</td> </tr> <tr> <td>505</td> <td>ARDESIA</td> <td>slate</td> </tr> </tbody> </table>	(*)	ECO-PELLE	ECO-PELLE	504	GRIGIO	grey	505	ARDESIA	slate																				
(*)	ECO-PELLE	ECO-PELLE																																			
504	GRIGIO	grey																																			
505	ARDESIA	slate																																			

**ESEMPI DI COMPONENTABILITA'**  
examples of compositions

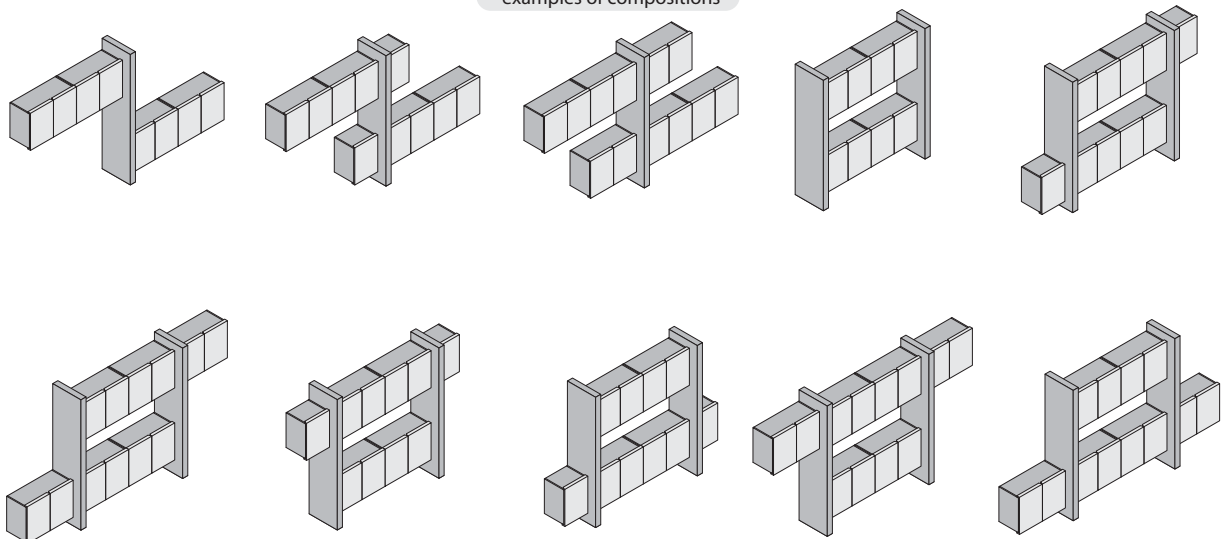

JERA

**MOBILI, TOP E FIANCHI FINALI**  
*cabinets, top and final side panels*

TUTTE LE COMPOSIZIONI CON I MOBILI CONTENITORI DEVONO ESSERE COMPLETATE CON TOP + 2 FIANCHI FINALI  
 always complete the compositions with top + 2 final side panels

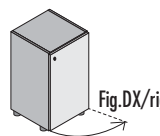
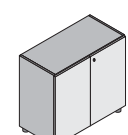
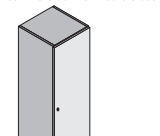
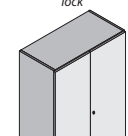
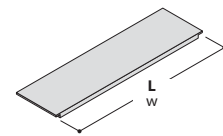
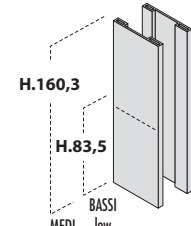
DESCRIZIONE <i>description</i>	L <i>w</i>	CODICE <i>code</i>	KG	M <sup>3</sup>	COLLI <i>PCS</i>	PREZZO <i>price</i>
MOBILE BASSO L.45 CON 1 ANTA LEGNO CON CHIUSURA AMMORTIZZATA E SERRATURA <i>low cabinet w 45 cms with 1 soft-close wooden door and lock</i>  Fig.DX/right L.45 x p.46,3 x H.81,5	DX right L.45	159 985 (*)	31	0,071	4	€ 167,00
	SX left L.45	159 986 (*)				
MOBILE BASSO L.90 CON 2 ANTE LEGNO CON CHIUSURA AMMORTIZZATA E SERRATURA <i>low cabinet w 90 cms with 2 soft-close wooden doors and lock</i>  L.90 x p.46,3 x H.81,5	L.90	159 987 (*)	43	0,107	4	€ 272,00
MOBILE MEDIO L.45 CON 1 ANTA LEGNO CON CHIUSURA AMMORTIZZATA E SERRATURA <i>medium cabinet w 45 cms with 1 soft-close wooden door and lock</i>  Fig.DX/right L.45 x p.46,3 x H.158,3	DX right L.45	159 988 (*)	47	0,134	5	€ 287,00
	SX left L.45	159 989 (*)				
MOBILE MEDIO L.90 CON 2 ANTE LEGNO CON CHIUSURA AMMORTIZZATA E SERRATURA <i>medium cabinet w 90 cms with 2 soft-close wooden doors and lock</i>  L.90 x p.46,3 x H.158,3	L.90	159 990 (*)	78	0,202	5	€ 498,00
TOPS PER MOBILI <i>tops for cabinets</i>  L. x p.51,6 x H.5	L.55	159 991 (*)	6	0,023	1	€ 104,00
	L.100	159 992 (*)	9	0,040	1	€ 180,00
	L.145	159 993 (*)	12	0,058	1	€ 257,00
	L.190	159 994 (*)	15	0,075	1	€ 329,00
	L.235	159 995 (*)	18	0,093	1	€ 391,00
	L.280	159 996 (*)	20	0,110	1	€ 449,00
<b>COMPLETARE SEMPRE CON FIANCHI FINALI</b> <i>always complete with final side panels</i> <b>ART.997-998</b>						
COPPIA FIANCHI FINALI PER MOBILI BASSI e MEDI <i>set of 2 final side panels for low and medium cabinets</i>  H.160,3 H.83,5 BASSI low MEDI medium sp.5 x p.51,6 x H.	H.83,5	159 997 (*)	21	0,058	1	€ 401,00
	H.160,3	159 998 (*)	39	0,109	1	€ 717,00
<b>COMPLETARE SEMPRE CON TOP</b> <i>always complete with top</i> <b>ART. 991-992-993-994-995-996</b>						

(*)	ANTE	STRUTTURA	doors	struttura
130	NOCE BALI	STONE GREY	bali walnut	stone grey
160	NOCE BALI	ANTRACITE	bali walnut	anthracite
730	FRASSINO BROWN	STONE GREY	brown ash	stone grey
830	OLMO GREY	STONE GREY	grey elm	stone grey
860	OLMO GREY	ANTRACITE	grey elm	anthracite

(*)	TOP	top
100	NOCE BALI	bali walnut
700	FRASSINO BROWN	brown ash
800	OLMO GREY	grey elm

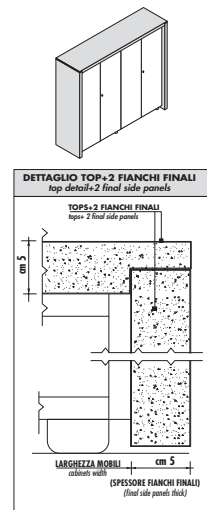

## DESCRIZIONE TECNICA

# JERA

### SCRIVANIE

Disponibili in due versioni:

- scrivania con fianco e schiena tappezzati in ECO-PELLE
- scrivania con fianco e schiena tappezzati in ECO-PELLE e allungo laterale

Dimensioni disponibili : L.1850-2100-2400 x p.1050 mm

Il piano ad alto spessore da 90 mm è realizzato con struttura a scocca autoportante costituito da :

>> fodera superiore e fasce perimetrali in pannello di MDF sp. 18 rivestito nella parte a vista, con 3d-foil effetto legno: OLMO GREY 12, NOCE BALI 30, FRASSINO BROWN 52.

>> fodera inferiore e intelaiatura strutturale interna costituita da pannello nobilitato melaminico sp. mm 18.

La schiena e il fianco sono realizzati con pannelli di particelle di legno sp. mm 18 accoppiati a sandwich per uno spessore totale di 90 mm., tappezzati nella parte a vista, con ECO-PELLE nei colori GRIGIO 504 e ARDESIA 505, supportata da ovatta di fibra acrilica sp. 12 mm, decorati con impunture lineari.

Nella parte inferiore, a contatto con il pavimento, sono inseriti scivoli in nylon nero sp. 10 mm dotati di feltrini autolivellanti.

L'unione strutturale tra piano e struttura di sostegno avviene tramite staffe di sostegno realizzate in lega di zama presso-fusa sp. mm 10, verniciate nero opaco, opportunamente sagomate con spigoli arrotondati e fissate tramite viti passo metrico 8ma.

### ALLUNGO e CASSETTIERA

Struttura interna realizzata con pannelli di particelle di legno sp. mm 18 colore ANTRACITE 55, rifiniti perimetralmente con bordo melaminico sp. mm 0,4 in tinta con la superficie.

Zoccolo, frontali, ante, schiena, fianchi finali e top realizzati con pannelli di fibre di legno tipo MDF sp. mm 18 rivestiti nella parte a vista, con 3d-foil effetto legno: OLMO GREY 12, NOCE BALI 30, FRASSINO BROWN 52. La struttura dei cassetti è costituita da spondine laterali realizzate con pannelli di particelle di legno sp. mm 12 nei colori ANTRACITE 55 e STONE GREY 44, rifiniti perimetralmente con bordo melaminico sp. mm 0,4 in tinta con la superficie, le quali scorrono su guide metalliche con cuscinetti in nylon dotati di fine corsa in apertura e chiusura ammortizzata.

Le ante e i cassetti sono dotate di sistema premi-apri.

L'allungo è da completare sempre con top-access (fornito separatamente)

### TOP-ACCESS

Disponibili in 2 tipologie: standard o multifunzione.

-Top-access standard realizzato in estruso di alluminio anodizzato colore nero satinato, con sportellino superiore aprile dotato di spazzolino parapolvere.

-Top-access multifunzione completo di cablaggio elettrico e dati, e dotato di sistema di chiusura elettrico a scomparsa.

Il cablaggio è costituito da : n° 2 prese Schuko ITALIA/GERMANIA, n°2 prese dati RJ45 Cat.6 e n°2 porte CHARGER USB, cavi di alimentazione da 2 metri.

Sistema di protezione automatico che impedisce la chiusura accidentale del coperchio se le prese sono inserite.

La cornice e la copertura superiore sono in acciaio verniciato nero spazzolato.

### PENISOLA FRONTALE

Dimensioni disponibili : L.1600 x p.800 mm

Il piano ad alto spessore da 90 mm è realizzato con struttura a scocca autoportante costituito da :

>> fodera superiore e fasce perimetrali in pannello di MDF sp. 18 rivestito nella parte a vista, con 3d-foil effetto legno: OLMO GREY 12, NOCE BALI 30, FRASSINO BROWN 52.

>> fodera inferiore e intelaiatura strutturale interna costituita da pannello nobilitato melaminico sp. mm 18.

La schiena e il fianco sono realizzati con pannelli di particelle di legno sp. mm 18 accoppiati a sandwich per uno spessore totale di 90 mm., tappezzati nella parte a vista, con ECO-PELLE nei colori GRIGIO 504 e ARDESIA 505, supportata da ovatta di fibra acrilica sp. 12 mm, decorati con impunture lineari.

Nella parte inferiore, a contatto con il pavimento, sono inseriti scivoli in nylon nero sp. 10 mm dotati di feltrini autolivellanti.

L'unione strutturale tra piano e struttura di sostegno avviene tramite staffe di sostegno realizzate in lega di zama presso-fusa sp. mm 10, verniciate nero opaco, opportunamente sagomate con spigoli arrotondati e fissate tramite viti passo metrico 8ma.

### TAVOLI RIUNIONE

Dimensioni disponibili : L.2100 e L.2800 x p.1200 mm

Il piano ad alto spessore da 90 mm è realizzato con struttura a scocca autoportante costituito da :

>> fodera superiore e fasce perimetrali in pannello di MDF sp. 18 rivestito nella parte a vista, con 3d-foil effetto legno: OLMO GREY 12, NOCE BALI 30, FRASSINO BROWN 52.

>> fodera inferiore e intelaiatura strutturale interna costituita da pannello nobilitato melaminico sp. mm 18.

Il piano è dotato di top access tipo flip-top ricavato direttamente sulla superficie ed in tinta con la stessa.

I fianchi sono realizzati con pannelli di particelle di legno sp. mm 18 accoppiati a sandwich per uno spessore totale di 90 mm., rivestiti nella parte a vista, con ECO-PELLE nei colori GRIGIO 504 e ARDESIA 505.

Nella parte inferiore, a contatto con il pavimento, sono inseriti scivoli in nylon nero sp. 10 mm dotati di feltrini autolivellanti.

La struttura è completata da due schiene di collegamento e un ripiano (per il supporto di cavi e prese elettriche), realizzati con pannelli di particelle di legno nobilitato melaminico sp. 18 mm, disponibili nei colori : ANTRACITE 55 e STONE GREY 44, rifiniti perimetralmente con bordo melaminico mm 0,4 in tinta con la superficie.

L'unione strutturale tra piano e struttura di sostegno avviene tramite staffe di sostegno realizzate in lega di zama presso-fusa sp. mm 10, verniciate nero opaco, opportunamente sagomate con spigoli arrotondati e fissate tramite viti passo metrico 8ma.

### TAVOLI DA SALOTTO

Dimensioni disponibili : quadrato L.800 x p.800, rettangolare L.1200x p.60 mm.

Il piano spessore totale 54 mm è realizzato in Folding con pannello di derivati del legno sp. 18 rivestito nella parte a vista, con 3d-foil effetto legno: OLMO GREY 12, NOCE BALI 30, FRASSINO BROWN 52.

I fianchi sono realizzati con pannelli di particelle di legno sp. mm 18 accoppiati a sandwich per uno spessore totale di 54 mm., rivestiti nella parte a vista, con ECO-PELLE nei colori GRIGIO 504 e ARDESIA 505. Nella parte inferiore, a contatto con il pavimento, sono inseriti scivoli in nylon nero sp. 10 mm. La struttura è completata da una schiena di collegamento realizzata con pannello di particelle di legno nobilitato melaminico sp. 18 mm, disponibile nei colori : ANTRACITE 55 e STONE GREY 44, rifinito perimetralmente con bordo melaminico mm 0,4 in tinta con la superficie.

### CONTENITORI TOTEM

Struttura realizzata con pannelli di particelle di legno sp. mm 18 nei colori ANTRACITE 55 e STONE GREY 44, rifiniti perimetralmente con bordo melaminico sp. mm 0,4 in tinta con la superficie. Sulla base sono inseriti 4 piedini livellatori di colore nero.

Sui due lati verticali sono inseriti profili incassati con corpi illuminanti a LED ad accensione/spengimento tramite sensori a sfioramento.

La struttura dei cassetti è costituita da spondine laterali realizzate con pannelli di particelle di legno sp. mm 12 nei colori ANTRACITE 55 e STONE GREY 44, rifiniti perimetralmente con bordo melaminico sp. mm 0,4 in tinta con la superficie. Le guide scorrevoli sono del tipo in metallo con cuscinetti in

nylon dotati di fine corsa in estrazione e self-closing in chiusura.

I ripiani in vetro sono realizzati con lastre float temperato fumee sp. mm 8 completi di supporti pressofusi cromati.

I frontali dei cassetti e le ante sono realizzati con pannelli di derivati del legno sp. 18 rivestiti nella parte a vista, con 3d-foil effetto legno: OLMO GREY 12, NOCE BALI 30, FRASSINO BROWN 52. Le ante e i cassetti sono dotate di sistema premi-apri.

Il grande frontale di finitura, di spessore totale 54 mm è sagomato con lavorazione a Folding ricavato da pannello di derivati del legno sp. 18 rivestito nella parte a vista, con 3d-foil effetto legno: OLMO GREY 12, NOCE BALI 30, FRASSINO BROWN 52.

#### **MOBILI SOSPESI**

Struttura e ripiano realizzati con pannelli di particelle legno sp. mm 18 nobilitati in melaminico, disponibili nei colori : ANTRACITE 55 e STONE GREY 44, rifiniti perimetralmente con bordo melaminico mm 0,4 in tinta con la superficie.

Il fissaggio a parete avviene tramite elementi a scomparsa registrabili con portata kg 60 cad.

Il ripiano è dotato di ferramenta a scomparsa, posizionabile in altezza con passo di 32mm.

Le ante sono realizzate con lavorazione a Folding su pannello di derivati del legno sp. 18 con il lato interno nobilitato in tinta con la struttura e le parti a vista rivestite in 3d-foil effetto legno nei colori: OLMO GREY 12, NOCE BALI 30, FRASSINO BROWN 52.

Sono dotate di incasso/maniglia sopra e sotto ed hanno sagoma avvolgente a "C" in verticale rispetto alla struttura.

Tutte le cerniere sono del tipo con ala e scatola metallica con 3 campi di regolazione e dotate di sistema di ammortizzamento soft-closing.

#### **SPALLA VERTICALE PER MOBILI SOSPESI**

Realizzata con pannelli di particelle di legno sp. mm 18 accoppiati a sandwich per uno spessore totale di 90 mm., tappezzati nella parte a vista, con ECO-PELLE nei colori GRIGIO 504 e ARDESIA 505.

Dotata di staffa metallica di fissaggio a muro. Nella parte inferiore, a contatto con il pavimento, sono inseriti scivoli in nylon nero con feltrini autolivellanti.

#### **MOBILI CONTENITORI BASSI E MEDI.**

Sono disponibili nelle larghezze cm 45 e cm 90 ed in 2 diverse tipologie in altezza: bassi e medi.

La struttura è realizzata con pannelli di particelle legno sp. mm 18 (i ripiani mm25) nobilitati in melaminico, disponibili nei colori : ANTRACITE 55 e STONE GREY 44, rifiniti perimetralmente con bordo melaminico mm 0,4 in tinta con la superficie ed è dotata di piedini livellatori.

Le ante sono realizzate con pannelli derivati del legno sp. mm 18 rivestiti nella parte a vista, con 3d-foil effetto legno nei colori: OLMO GREY 12, NOCE BALI 30, FRASSINO BROWN 52.

Le ante legno basse e medie sono dotate di serratura a paletto e sistema di ammortizzamento soft-closing.

**Le composizioni dei mobili sono da completare sempre con top di finitura e fianchi finali (forniti a parte) .**

#### **TOP E FIANCHI FINALI :**

Sono realizzati con lavorazione a Folding di spessore totale 50 mm. Materiale costituito da pannello di derivati del legno sp. 18 con la parte a vista rivestita in 3d-foil effetto legno nei colori: OLMO GREY 12, NOCE BALI 30, FRASSINO BROWN 52.

#### **IMBALLO**

Tutti i componenti sono forniti smontati ed imballati con involucro pieghevole in cartone triplo, listelli di protezione perimetrale e per i riempimenti ove occorre. Gli angoli sono protetti, ove occorre, con parasigoli anti-urto. La chiusura dell'imballo avviene mediante nastro adesivo e reggetta in nylon termosaldato.

Le cassettiere sono fornite montate, protette sui lati con angolari in polistirolo ed imballate con foglia di polietilene termoretraibile.

CARATTERISTICHE FISICO-MECCANICHE DEI PANNELLI DI PARTICELLE DI LEGNO DI SPESSORE mm 18 NOBILITATI IN MELAMINICO:		
DESCRIZIONE	VALORE MINIMO	NORMA DI RIFERIMENTO
Massa volumica	650 Kg / m <sup>3</sup> ± 10%	UNI EN 323 :1994
Umidità relativa	5 - 13%	UNI EN 322 :1994
Tolleranza spessore	± 0,3 mm	UNI EN 324-1/1994
Rigonfiamento a 24 ore	15%	UNI EN 317 :1994
Distacco strati esterni	0,8 Mpa	UNI EN 311 :2003
Flessione statica	16 Mpa	UNI EN 310 :1994
Modulo di elasticità	1600 Mpa	UNI EN 310 :1994
Estrazione viti sui bordi	> 400 N	UNI EN 320 :1994
Contenuto di formaldeide	≤ a 3,5 mg H2CO (m <sup>2</sup> x h)	UNI EN ISO 12460 - 3:2015

Emesso da Ufficio Tecnico LAS MOBILI  
Data ultima revisione:  
GENNAIO 2020

## TECHNICAL DESCRIPTION

# JERA

### DESKS

Available in two versions:

- desk with side and back panel upholstered in ECO-PELLE
- desk with side and back panel upholstered in ECO-PELLE and lateral extension.

Available sizes: Wd.2400 and Wd.2100 x Dpt.1050 mm

The extra thick 90 mm top is made in a self-supporting shell structure composed of:

>> upper lining and perimetral band in 18 mm thick MDF panel, with visible parts coated with wood effect 3d foil: GREY ELM 12, BALI WALNUT 30, BROWN ASH 52.

>> lower lining and internal structural frame composed of 18 mm thick melamine faced panel.

The back panel and sides are made in 18 mm thick chipboard panels, sandwich joined for a total thickness of 90mm, upholstered on the visible part with ECO-PELLE in the colours GREY 504 and SLATE 505, supported by acrylic fibre batting, thickness 12 mm, decorated with linear stitching.

In the lower part, in contact with the floor, 10 mm thick black nylon slides are inserted, equipped with self-levelling felt pads.

The top and support structure are joined using support brackets in a die-cast zamak alloy, thickness 10 mm, painted in matt black, compatibly shaped with rounded edges and fastened using 8ma screws.

### EXTENSION AND PEDESTAL

Internal structure made with 18 mm thick chipboard panels in ANTHRACITE 55, finished along the perimeter with a 0.4 mm thick melamine edge in the same colour as the surface.

Plinth, front panels, doors, back panel, final sides and top made in 18 mm thick MDF fibreboard panels, with the visible part coated with wood effect 3d foil: GREY ELM 12, BALI WALNUT 30, BROWN ASH 52.

The drawer structure is made with 12 mm thick chipboard panels in colours ANTHRACITE 55 and STONE GREY, finished along the perimeter with a 0.4 mm thick melamine edge in the same colour as the surface, which slide along metal guides with nylon bearings, equipped with drawer stop for opening and soft-close mechanism.

The doors and drawers are fitted with a push release mechanism.

The extension is to be completed with a top-access (supplied separately)

### TOP-ACCESS

Available in two types: standard or multi-purpose

- Standard top-access made in anodised aluminium extrusion, satin-finished black colour, with openable upper hatch door fitted with dust protection brush.

- Multi-purpose top-access complete with electrical wiring and data, equipped with electrical disappearing closing system.

Wiring consists in: no.2 Schuko sockets (ITALY-GERMANY), no.2 RJ45 Cat.6 data sockets and no.2 CHARGER USB ports, 2 meters long power cables.

The side laser sensor detects the presence of plugs, preventing accidental closing when installed.

Border and cover are in black brushed painted steel.

### FRONT TERMINAL

Available sizes: Wd.1600 x Dpt.800 mm

The extra thick 90 mm top is made in a self-supporting shell structure composed of:

>> upper lining and perimetral band in 18 mm thick MDF panel, with visible part coated with wood effect 3d foil: GREY ELM 12, BALI WALNUT 30, BROWN ASH 52.

>> lower lining and internal structural frame composed of 18 mm thick melamine faced panel.

The back panel and sides are made in 18 mm thick chipboard panels, sandwich joined for a total thickness of 90mm, upholstered on the visible part with ECO-PELLE in the colours GREY 504 and SLATE 505, supported by acrylic fibre batting, thickness 12 mm, decorated with linear stitching.

In the lower part, in contact with the floor, 10 mm thick black nylon slides are inserted, equipped with self-levelling felt pads.

The top and support structure are joined using support brackets in a die-cast zamak alloy, thickness 10 mm, painted in matt black, compatibly shaped with rounded edges and fastened using 8ma screws.

### MEETING TABLES

Available sizes: Wd.2100 and Wd.2800 x Dpt.1200 mm

The extra thick 90 mm top is made in a self-supporting shell structure composed of:

>> upper lining and perimetral band in 18 mm thick MDF panel, with visible part coated with wood effect 3d foil: GREY ELM 12, BALI WALNUT 30, BROWN ASH 52.

>> lower lining and internal structural frame composed of 18 mm thick melamine faced panel.

The top is fitted with a flip-flop type top-access built-in to the top and in the same colour.

The sides are made in 18 mm thick chipboard panels, sandwich joined for a total thickness of 90mm, upholstered on the visible part with ECO-PELLE in the colours GREY 504 and SLATE 505.

In the lower part, in contact with the floor, 10 mm thick black nylon slides are inserted, equipped with self-levelling felt pads.

The structure is completed by two connecting back panels and a shelf (for support of cables and sockets), made in 18 mm thick melamine faced chipboard and available in the colours: ANTHRACITE 55 and STONE GREY 44, finished along the perimeter with a 0.4 mm melamine edge, in the same colour as the surface.

The top and support structure are joined using support brackets in a die-cast zamak alloy, thickness 10 mm, painted in matt black, compatibly shaped with rounded edges and fastened using 8ma screws.

### COFFEE TABLES

Available sizes: square Wd.800 x Dpt.800, rectangular Wd.1200 x Dpt.60 mm.

The top with total thickness 54 mm is made with a Folding system with 18 mm panels of reconstituted wood, with visible part coated with wood effect 3d foil: GREY ELM 12, BALI WALNUT 30, BROWN ASH 52.

The sides are made in 18 mm thick chipboard panels, sandwich joined for a total thickness of 54mm, upholstered on the visible part with ECO-PELLE in the colours GREY 504 and SLATE 505. In the lower part, in contact with the floor, 10 mm thick black nylon slides are inserted. 10 mm. The structure is completed by a connecting back panel, made in 18 mm thick melamine faced chipboard and available in the colours: ANTHRACITE 55 and STONE GREY 44, finished along the perimeter with a 0.4 mm melamine edge, in the same colour as the surface.

### TOTEM CABINETS

Structure made with 18 mm thick chipboard panels in ANTHRACITE 55 and STONE GREY 44, finished along the perimeter with a 0.4 mm thick melamine edge, in the same colour as the surface. On the base there are 4 black levelling feet.

On the two vertical sides, built-in profiles are inserted, with LED lights controlled by movement sensors.

The structure of drawers are composed of lateral sides in 12 mm thick chipboard panels in colours ANTHRACITE 55 and STONE GREY, finished along the perimeter with a 0.4 mm thick melamine edge in the same colour as the surface.

The sliding guides are in metal with nylon bearings, equipped with drawer stop for opening and self-closing mechanism.  
 The glass planes are made in 8 mm thick tempered smoked float glass, complete with die-cast chrome-plated supports.  
 Fronts of drawers and door are made from 18 mm thick panels of reconstituted wood, with visible part coated with wood effect 3d foil. GREY ELM 12, BALI WALNUT 30, BROWN ASH 52. The doors and drawers are fitted with a push release mechanism.  
 The large front finish panel, with total thickness 54 mm is shaped with a Folding system, made from an 18 mm thick panel of reconstituted wood, with visible part coated with wood effect 3d foil: GREY ELM 12, BALI WALNUT 30, BROWN ASH 52.

#### SUSPENDED CABINETS

Structure and shelving made using 18 mm thick chipboard panels, melamine faced and available in the colours: ANTHRACITE 55 and STONE GREY 44, finished along the perimeter with a 0.4 mm melamine edge, in the same colour as the surface.  
 Units fastened to wall using adjustable disappearing elements, each with a capacity of 60 kg.  
 The shelf is fitted with disappearing hardware, positionable at height at an interval of 32mm.  
 Doors are made with a Folding system on an 18 mm thick panel of reconstituted wood, with melamine faced internal side in the same colour as the structure, and the visible part coated in wood effect 3d foil in the colours: GREY ELM 12, BALI WALNUT 30, BROWN ASH 52.  
 They are fitted with recess/handle above and below, with an enveloping "C" shape, vertical to the structure.  
 All hinges are the type with wing and metal plate with 3 regulation ranges and equipped with shock-absorbing soft-close system.

#### VERTICAL PANEL FOR SUSPENDED CABINETS

Made in 18 mm thick chipboard panels, sandwich joined for a total thickness of 90mm, upholstered on the visible part with ECO-PELLE in the colours GREY 504 and SLATE 505.  
 Fitted with metal bracket for fastening to the wall. In the lower part, in contact with the floor, 10 mm thick black nylon slides are inserted with self-levelling felt pads.

#### LOW & MEDIUM STORAGE CABINETS.

These are available in widths of 45 cm and 90 cm and in two different heights: low and medium.  
 Structure made using 18 mm thick chipboard panels (shelves 25 mm), melamine faced and available in the colours: ANTHRACITE 55 and STONE GREY 44, finished along the perimeter with a 0.4 mm melamine edge, in the same colour as the surface and fitted with levelling feet.  
 Doors are made in 18 mm panels deriving from wood, with visible part coated with wood effect 3d foil in the colours: GREY ELM 12, BALI WALNUT 30, BROWN ASH 52. Low and medium wooden doors are fitted with a latch lock and shock-absorbing soft-close system.  
 Furniture compositions are always to be completed with top finish+final sides (supplied separately).

#### TOP & FINAL SIDES PANELS:

These are made with a Folding system, with total thickness 50 mm. Material composed of 18 mm thick reconstituted wood panels, with the visible part coated in wood effect 3d foil in the colours: GREY ELM 12, BALI WALNUT 30, BROWN ASH 52.

#### PACKAGING

All the components are disassembled and packed when supplied, and have paper triple type folding packaging, fillets for the perimetrical protection and for the fillings up, where needed. The corners are protected, where needed, through shock resistant edges protector. The packing closure occurs through sticky tape and welded nylon strap. Pedestals are assembled, when supplied, protected through polystyrene angle bars on the sides and packed using thermo-retractable polyethylene leave when provided.

PHYSICAL-MECHANICAL CHARACTERISTICS OF 18 MM THICK PARTICLEBOARD PANELS, MELAMINE-FACED:		
DESCRIPTION	MINIMUM VALUE	STANDARD NUMBERS
Volume Mass	650 Kg / m <sup>3</sup> ± 10%	UNI EN 323 :1994
Relative Humidity	5 - 13%	UNI EN 322 :1994
Thickness Allowance	± 0,3 mm	UNI EN 324-1/1994
24 hour Swelling	15%	UNI EN 317 :1994
External Surfaces Detachment	0,8 Mpa	UNI EN 311 :2003
Static Flexure	16 Mpa	UNI EN 310 :1994
Elastic Modulus	1600 Mpa	UNI EN 310 :1994
Edge Screws Extraction	> 400 N	UNI EN 320 :1994
Formaldehyde Content	≤ a 3,5 mg H <sub>2</sub> CO (m <sup>2</sup> x h)	UNI EN ISO 12460 - 3:2015

Released by the Technical Office of LAS MOBILI  
 last revision date:  
 JANUARY 2020

**INDICE DEI CODICI**  
codes index

\* = INDICARE IL CODICE FINITURA  
= complete with finish code

INDICE DEI CODICI  
codes index  
Mod. JERA

CODICE code	DESCRIZIONE description	NOTE notes	PAG. page	PREZZO price
159 910 *	PENISOLA FRONTALE PER SCRIVANIE L.160 x p.80 front terminal for desk w 160 x d 80		6	€ 1.336,00
159 911 *	TAVOLO DA SALOTTO QUADRATO L.80 x p.80 squared coffee table w 80 x d 80 cms		6	€ 557,00
159 912 *	TAVOLO DA SALOTTO RETTANGOLARE L.120 x p.60 rectangular coffee table w 120 x d 60 cms		6	€ 616,00
159 913 *	TAVOLO RIUNIONE L.210 x p.120 meeting table w 210 x d 120 cms		6	€ 2.025,00
159 914 *	TAVOLO RIUNIONE L.280 x p.120 meeting table w 280 x d 120 cms		6	€ 2.458,00
159 917 *	SCRIVANIA DIREZIONALE L.210 CON FIANCO DX executive desk w 210 cms with right side panel	CON SCHIENA CHIUSA with close back panel	4	€ 2.410,00
159 919 *	SCRIVANIA DIREZIONALE L.240 CON FIANCO DX executive desk w 240 cms with right side panel	CON SCHIENA CHIUSA with close back panel	4	€ 2.585,00
159 921 *	SCRIVANIA DIREZIONALE L.210 CON FIANCO SX executive desk w 210 cms with left side panel	CON SCHIENA CHIUSA with close back panel	4	€ 2.410,00
159 923 *	SCRIVANIA DIREZIONALE L.240 CON FIANCO SX executive desk w 240 cms with left side panel	CON SCHIENA CHIUSA with close back panel	4	€ 2.585,00
159 927 *	SCRIVANIA DIREZIONALE L.210 CON FIANCO DX E ALLUNGO SX executive desk w 210 cms with right side panel and left extension	CON SCHIENA CHIUSA with close back panel	4	€ 3.422,00
159 929 *	SCRIVANIA DIREZIONALE L.240 CON FIANCO DX E ALLUNGO SX executive desk w 240 cms with right side panel and left extension	CON SCHIENA CHIUSA with close back panel	4	€ 3.597,00
159 931 *	SCRIVANIA DIREZIONALE L.210 CON FIANCO SX E ALLUNGO DX executive desk w 210 cms with left side panel and right extension	CON SCHIENA CHIUSA with close back panel	4	€ 3.422,00
159 932 *	SOTTOMANO PER SCRIVANIE desk pad		5	€ 260,00
159 933 *	SCRIVANIA DIREZIONALE L.240 CON FIANCO SX E ALLUNGO DX executive desk w 240 cms with left side panel and right extension	CON SCHIENA CHIUSA with close back panel	4	€ 3.597,00
159 935 *	CASSETTIERA LATERALE DX CON 2 CASSETTI right lateral pedestal 2 drawers		5	€ 654,00
159 936 *	CASSETTIERA LATERALE SX CON 2 CASSETTI left lateral pedestal 2 drawers		5	€ 654,00
159 947 *	SCRIVANIA DIREZIONALE L.210 CON FIANCO DX executive desk w 210 cms with right side panel	CON SCHIENA APERTA with open back panel	4	€ 2.147,00
159 949 *	SCRIVANIA DIREZIONALE L.240 CON FIANCO DX executive desk w 240 cms with right side panel	CON SCHIENA APERTA with open back panel	4	€ 2.321,00
159 950 *	SCRIVANIA DIREZIONALE L.210 CON FIANCO SX executive desk w 210 cms with left side panel	CON SCHIENA APERTA with open back panel	4	€ 2.147,00
159 952 *	SCRIVANIA DIREZIONALE L.240 CON FIANCO SX executive desk w 240 cms with left side panel	CON SCHIENA APERTA with open back panel	4	€ 2.321,00
159 953 *	SCRIVANIA DIREZIONALE L.210 CON FIANCO DX E ALLUNGO SX executive desk w 210 cms with right side panel and left extension	CON SCHIENA APERTA with open back panel	4	€ 3.159,00
159 955 *	SCRIVANIA DIREZIONALE L.240 CON FIANCO DX E ALLUNGO SX executive desk w 240 cms with right side panel and left extension	CON SCHIENA APERTA with open back panel	4	€ 3.333,00
159 956 *	SCRIVANIA DIREZIONALE L.210 CON FIANCO SX E ALLUNGO DX executive desk w 210 cms with left side panel and right extension	CON SCHIENA APERTA with open back panel	4	€ 3.159,00
159 958 *	SCRIVANIA DIREZIONALE L.240 CON FIANCO SX E ALLUNGO DX executive desk w 240 cms with left side panel and right extension	CON SCHIENA APERTA with open back panel	4	€ 3.333,00
159 959 *	TOP ACCESS STANDARD standard top access		5	€ 85,00
159 960 *	TOP ACCESS MULTIFUNZIONE (2 PRESE STANDARD GERMANIA SCHUKO+2 RJ 45 CAT.6 + 2 USB multifunctions top access (2 Germany standard sockets schuko+2 RJ 45 CAT.6+2 USB)		5	€ 578,00
159 961 *	SCRIVANIA DIREZIONALE L.185 CON FIANCO DX executive desk w 185 cms with right side panel	CON SCHIENA APERTA with open back panel	4	€ 2.060,00
159 962 *	SCRIVANIA DIREZIONALE L.185 CON FIANCO SX executive desk w 185 cms with left side panel	CON SCHIENA APERTA with open back panel	4	€ 2.060,00
159 963 *	SCRIVANIA DIREZIONALE L.185 CON FIANCO DX E ALLUNGO SX executive desk w 185 cms with right side panel and left extension	CON SCHIENA APERTA with open back panel	4	€ 3.072,00
159 964 *	SCRIVANIA DIREZIONALE L.185 CON FIANCO SX E ALLUNGO DX executive desk w 185 cms with left side panel and right extension	CON SCHIENA APERTA with open back panel	4	€ 3.072,00
159 965 *	MOBILE TOTEM CON ANTA DX O SX (H.221,6) totem cabinet with right or left wooden door (H.221,6)		7	€ 1.086,00
159 966 *	MOBILE TOTEM CON ANTA DX O SX E 2 CASSETTI (H.221,6) totem cabinet with right or left wooden door and 2 drawers (H.221,6)		7	€ 1.274,00
159 968 *	MOBILE TOTEM CON ANTA DX O SX (H.260) totem cabinet with right or left wooden door (H.260)		7	€ 1.270,00
159 969 *	MOBILE TOTEM CON ANTA DX O SX E 2 CASSETTI (H.260) totem cabinet with right or left wooden door and 2 drawers (H.260)		7	€ 1.457,00
159 976 *	MOBILE SOSPESO L.45 CON 1 ANTA LEGNO DX O SX CON CHIUSURA AMMORTIZZATA suspended cabinet w 45 cms with 1 soft-close right or left wooden door		9	€ 244,00
159 980 *	MOBILE SOSPESO L.90 CON 2 ANTE LEGNO CON CHIUSURA AMMORTIZZATA suspended cabinet w 90 cms with 2 soft-close wooden doors		9	€ 362,00
159 983 *	SPALLA VERTICALE TAPPEZZATA H.220 upholstered vertical panel H.220		9	€ 498,00

JERA

\* = INDICARE IL CODICE FINITURA  
= complete with finish code

INDICE DEI CODICI  
codes index  
Mod. JERA

CODICE code	DESCRIZIONE description	NOTE notes	PAG. page	PREZZO price
159 985 *	MOBILE BASSO L.45 CON 1 ANTA LEGNO DX CON CHIUSURA AMMORTIZZATA E SERRATURA low cabinet w 45 cms with 1 soft-close right wooden door and lock		10	€ 167,00
159 986 *	MOBILE BASSO L.45 CON 1 ANTA LEGNO SX CON CHIUSURA AMMORTIZZATA E SERRATURA low cabinet w 45 cms with 1 soft-close left wooden door and lock		10	€ 167,00
159 987 *	MOBILE BASSO L.90 CON 2 ANTE LEGNO CON CHIUSURA AMMORTIZZATA E SERRATURA low cabinet w 90 cms with 2 soft-close wooden doors and lock		10	€ 272,00
159 988 *	MOBILE MEDIO L.45 CON 1 ANTA LEGNO DX CON CHIUSURA AMMORTIZZATA E SERRATURA medium cabinet w 45 cms with 1 soft-close right wooden door and lock		10	€ 287,00
159 989 *	MOBILE MEDIO L.45 CON 1 ANTA LEGNO SX CON CHIUSURA AMMORTIZZATA E SERRATURA medium cabinet w 45 cms with 1 soft-close left wooden door and lock		10	€ 287,00
159 990 *	MOBILE MEDIO L.90 CON 2 ANTE LEGNO CON CHIUSURA AMMORTIZZATA E SERRATURA medium cabinet w 90 cms with 2 soft-close wooden doors and lock		10	€ 498,00
159 991 *	TOP PER MOBILI L.55 top for cabinets w 55 cms		10	€ 104,00
159 992 *	TOP PER MOBILI L.100 top for cabinets w 100 cms		10	€ 180,00
159 993 *	TOP PER MOBILI L.145 top for cabinets w 145 cms		10	€ 257,00
159 994 *	TOP PER MOBILI L.190 top for cabinets w 235 cms		10	€ 329,00
159 995 *	TOP PER MOBILI L.235 top for cabinets w 235 cms		10	€ 391,00
159 996 *	TOP PER MOBILI L.280 top for cabinets w 280 cms		10	€ 449,00
159 997 *	COPPIA FIANCHI FINALI PER MOBILI BASSI set of 2 final side-panels for low cabinets		10	€ 401,00
159 998 *	COPPIA FIANCHI FINALI PER MOBILI MEDI set of 2 final side-panels for medium cabinets		10	€ 717,00